

#5600 PANTHER[®] PROPANE POWERED FLOOR PREP SYSTEM INSTRUCTION MANUAL



Read Manual Before Operating Machine



National
Flooring Equipment, Inc.



9250 XYLON AVENUE NORTH • MINNEAPOLIS, MN 55445 • U.S.A.
800-245-0267 • 763-535-8206 • FAX 763-535-8255 • FAX 800-648-7124
WEB SITE: www.nationalequipment.com • E-MAIL: info@nationalequipment.com

TABLE OF CONTENTS

■ Table of Contents	2-5
■ Hydraulic Safe Operation	6-7
A. Maintaining A Safe Work Environment	6
B. Pressure.....	6-7
C. Flammability	7
D. Hydraulic Fluid.....	7
■ Rules for Safe Operation.....	8-10
A. General Rules	8-9
B. Characteristics of a Defensive Operator	10
■ Safety Instructions/ Precautions	11-12
■ Battery Safe Operation.....	13
A. First Aid	13
B. Ventilation	13
■ Motor Safe Operation	14
■ Troubleshooting.....	15-16
■ Features/Specifications	17-18
A. Vibration/Sound Data	18
■ Operating Controls	19-22
A. Start-Up Procedure	19
B. Throttle Control	19
C. Hydraulic Levers	19-20
D. Seat Switch	20
E. Cylinder Lift	20
F. Shut-Down Mode	21
G. Machine Storage	21
H. Changing Propane Tank	22
i. Carbon Monoxide Information and Warnings	22
■ Operational Tips	23
A. Caster	23
B. Foot Peg	23
C. Seat.....	23
D. Disarm Machine	23
E. Turn Machine Off.....	23
F. Leakage	23
G. Angle of the Head is Set Steep.....	23
H. Raising or Lowering the Slide Plate	23

TABLE OF CONTENTS

■ Loading/Unloading	24-25
A. Dock Heights	24
B. Power-Gate	24
C. Ramps	24
D. Forklift Cups	25
E. Winches	25
F. Transporting	25
G. Wheel Chocks	25
■ Center of Gravity	26
■ Job Site Movement	27-28
A. Taping Wheels.....	27
B. Leap Frogging Boards.....	27
C. Palletizing	27
D. Front Wheel Assembly	27
E. To Move Machine Without Power	28
F. Moving Machine on Caster	28
■ Wheel Sizes	29
A. Wheel Size	29
■ Cutting Heads and Blades.....	30-32
A. Dialing in the Machine.....	30
B. Saving Time with Extra Cutting Heads	30
C. Adjusting Slide Plate and Cutting Head	30
D. Shear Point	30
E. Weight vs. Sharpness	31
F. Cutting Head Angle	31
G. Steep Cutting Head Angle.....	31
H. Swivel Head	31
I. Cutting Head Insertion	31
J. Shank Blade Insertion	32
K. Blade Setting.....	32
L. Self-Scoring Blades.....	32
M. Blade Insertion or Blade Changing	32
■ Blade Application/Set-Up	33-35
A. Ceramic Set-Up.....	33
B. Wood Set-Up.....	33
C. Secondary Backing Carpet Set-Up	33
D. Foam Back Carpet Set-Up	33

TABLE OF CONTENTS

E. Double Stick Carpet Set-Up	33
F. VCT Tile Set-Up	33
G. Rubber Tile Set-Up	33
H. Re-Scraping Set-Up	34
I. Thin Coating Set-Up	34
J. Working Over Concrete.....	34
K. Working Over Wood	34
L. Working Over Soft Sub-Floor	34
M. Cross Room Ditching	35
N. Checker Board Ditching	35
■ Blades	36-39
A. Types of Blades.....	36
B. Blade Sharpening	37
C. Self-Scoring Blade Sharpening.....	37
D. Carbide Tipped Blade Sharpening	37
E. Blade Selection Chart	38-39
■ Machine Maintenance	40-46
A. Maintenance & Inspection List	40
B. Slide Plate	41
C. Lower Cutting Head Support.....	41
D. Leak Maintenance.....	41
E. Oil Level & Hydraulic Oil Change Out.....	42
F. Hydraulic Cylinder Change Out.....	42
G. Engine Oil Change Out	43
H. Hose Change Out	43
I. Foot Peg	43
J. Pump Change Out	43
K. Valve Change Out.....	43
L. Engine Change Out.....	44
M. Wheel Motor Change Out	44
N. Wheel Changing	44
O. Changing Hydraulic Fluid Filter	45
P. Changing Engine Air Filter	45
Q. Caster Maintenance	45
R. Engine Maintenance	45
S. Switches	46
T. Seat Replacement.....	46
U. Debris Deflector Mounting Instructions	47

TABLE OF CONTENTS

■ Complete Parts List.....	48-52
■ Part Numbers and Diagrams	53-66
A. External Parts	53
B. External Parts	54
C. Beeper & Hood Parts	55
D. Gear Pump Parts.....	56
E. Wheel Parts.....	57
F. Control Lever Parts	58
G. Single Spool & Hose Parts	59
H. Double Spool & Hose Parts.....	60
I. Filter & Tank Parts.....	61
J. Cylinder Parts.....	62
K. Slide Plate/Deflector, Caster & Foot Peg Parts	63
L. Propane Tank Parts.....	64
M. Engine Battery.....	65
N. Battery/Weights	66
■ Labels.....	67-68
■ Accessories	69
■ Blades & Cutting Heads	70-71
■ Wiring Diagrams	72
■ Material Safety Data.....	73-78
■ Fire Extinguisher Material Safety Data.....	79-85
■ Guarantee	86
■ Return Sheet	87
■ Blade Order Form	88-89
■ Kawasaki Engine Manual.....	Insert

HYDRAULIC SAFE OPERATION

MAINTAINING A SAFE WORK ENVIRONMENT

Establishing a safe working environment in and around your hydraulic equipment is just common sense. The easiest and most effective way to avoid problems is to make sure associates understand their equipment, know how to operate it safely and recognize the danger it represents if handled carelessly. A few things you must be aware of include:

1. **PRESSURE:** Hydraulic fluid under pressure is dangerous and can cause serious injury.
2. **FLAMMABILITY:** When ignited, some hydraulic fluids can explode and/or cause fires.
3. **MECHANICAL:** Hydraulic fluid creates movement, which causes parts of your equipment to move or rotate. Always be aware of what you are doing.
4. **MOISTURE:** Use caution when operating in wet or high moisture conditions. Make sure all electrical fittings, switches, cords plus strain reliefs are in good condition. Always unplug when not in use and when doing any service work.
5. **ELECTRICAL:** Faulty wiring can also be an electrical hazard. A regular preventive maintenance program should always include a wiring check. Unplug batteries and/or charger before servicing.
6. **TEMPERATURE:** Because this machine operates at a relatively low pressure, overheating is not common. If surface of tank becomes too hot to touch by hand (above 130°), shut off machine and allow to cool off.

PRESSURE

Our system runs at or below 2,000 psi. Never look for a leak when unit is under pressure. Using your hand could cause serious injury. A few common ways to encounter hydraulic fluid under pressure include:

1. **PINHOLE:** Fluid under pressure can cause serious injury. It can be almost invisible escaping from a pinhole, and it can pierce the skin into the body. Do not touch a pressurized hydraulic hose assembly with any part of your body. If fluid punctures the skin, even if no pain is felt, a serious emergency exists. Obtain medical assistance immediately. Failure to do so can result in loss of the injured part or death.
2. **LEAK:** Keep fittings and hoses tight. Only check and service when not under pressure. Leaking hydraulic fluid is not only unsightly, it's hazardous. In addition to making workplace floors slippery and dangerous, leaks also contaminate the environment. Before cleaning an oil spill, always check EPA, state and local regulations.

LEAK AT THREAD END/SEAT

Problem: Coupling leaks at thread or seat. This may be caused by any of the following:

- a. Missing or damaged O-rings.
- b. Damaged threads or seat angle.
- c. Thread alignment.
- d. Incompatible thread ends or seat angles.
- e. Over or under torquing.

Solution: Remove the connection and inspect.

1. Certain couplings require the use of an O-ring. If it is missing, replace it. If an O-ring is used, check for damage caused by installation or possible material breakdown from heat or fluid incompatibility. Alternative O-ring materials may be required. Replace if necessary.
2. Check the threads and/or seat angle for damage that may have occurred prior to or during installation. Any ding or burr may be a potential leak path. Replace if necessary.

HYDRAULIC SAFE OPERATION

PRESSURE (continued)

3. If the coupling was misaligned during installation, threads may have been damaged. Replace and carefully install.
4. Over torquing of a threaded connection can stretch and damage threads and mating seat angles. Over torquing can also damage the staking area of the nut. Under torquing does not allow proper sealing.

⚠ CAUTION: Never check for leaks over hose or hydraulic connections. Instead, use a piece of cardboard to locate a pressurized leak. For drips (low pressure leaks), use a rag to clean the area and determine where the leak originates.

⚠ CAUTION: Never touch a pressurized hose assembly. Shut down the hydraulic system before checking hose temperature.

3. **BURST:** Whether due to improper selection or damage, a ruptured hose can cause injury. If it bursts, a worker can be burned, cut, injected or may slip and fall.
4. **COUPLING BLOW-OFF:** If the assembly is not properly made or installed, the coupling could come off and hit or spray a worker, possibly resulting in serious injury. Never operate machine without guards.

FLAMMABILITY

With the exception of those comprised primarily of water, all hydraulic fluid is flammable when exposed to the proper conditions (including many “fire-resistant” hydraulic fluids).

Leaking pressurized hydraulic fluids may develop a mist or fine spray that can flash or explode upon contact with a cause of ignition. These explosions can be very severe and could result in serious injury or death.

Precautions should be taken to eliminate all ignition sources from contact with escaping fluids, sprays or mists resulting from hydraulic failures. Sources of ignition could be electrical discharges (sparks), open flames, extremely high temperatures, sparks caused by metal-to-metal contact, etc.

HYDRAULIC FLUID

Only use Texaco Rando 46 Hydraulic Oil or Compatible Fluid like IS032. Non-compatible fluids could cause damage to unit or serious injury.

⚠ WARNING: When using electric tools, always follow basic safety precautions to reduce the risk of electric shock and personal injury.

RULES FOR SAFE OPERATION



READ AND SAVE ALL INSTRUCTIONS FOR FUTURE USE. Before use, be sure everyone operating this equipment reads and understands this manual as well as any labels packaged with or attached to the machine and components and view the instruction video. Extra copies of the manual and video are available. In cases where personnel have an insufficient knowledge of the English language, proper training must be obtained before using the 5600 machine.

- 1. KNOW YOUR EQUIPMENT:** Read this manual and view instruction video carefully to learn equipment applications and limitations as well as potential hazards associated with this type of equipment.

⚠ WARNING: Disarm machine when not in use. Remove Cutting Head or lower Cutting Head to the floor. When exiting machine (getting off machine), remove lower Cutting Head to the floor. When transporting machine around job site, remove Cutting Head. Failure to follow these instructions could cause severe bodily injury.

- 2. DISARM MACHINE:** Remove cutting head or drop cutting head to the floor when machine is not in use.
- 3. DO NOT "SIDE HILL" MACHINE:** See Page 24 & 26.
- 4. AVOID DANGEROUS ENVIRONMENTS:** Do not use in rain, damp or wet locations, or in the presence of explosive atmospheres (gaseous fumes, dust or flammable materials). Remove materials or debris that may be ignited by sparks.
- 5. KEEP WORK AREA CLEAN AND WELL LIT:** Cluttered, dark work areas invite accidents.
- 6. DRESS PROPERLY:** Do not wear loose clothing. These may be caught in moving parts. Keep hands and gloves away from moving parts.
- 7. USE SAFETY EQUIPMENT:** Everyone in the work area should wear safety goggles or glasses complying with current safety standards. Wear hearing protection during extended use and a dust mask for dusty operations. Hard hats, face shields, safety shoes, etc. should be worn when specified or necessary.
- 8. KEEP BYSTANDERS AWAY:** Children and bystanders should be kept at a safe distance from the work area to avoid distracting the operator. Operator should be aware of who is around them and their proximity.
- 9. PROTECT OTHERS IN THE WORK AREA:** Provide barriers or shields as needed to protect others from debris and machine operation.
- 10. USE PROPER ACCESSORIES:** Using accessories that are not recommended may be hazardous. Be sure accessories are properly installed and maintained. Do not delete a guard or other safety device when installing an accessory, attachment or servicing.
- 11. CHECK FOR DAMAGED PARTS:** Inspect guards and other parts before use. Check for misalignment, binding of moving parts, improper mounting, broken parts and any other conditions that may affect operation. If abnormal noise or vibration occurs, turn the tool off immediately and have the problem corrected before further use. Do not use damaged equipment. Tag damaged machine "DO NOT USE" until repaired. A guard or other damaged parts should be properly repaired or replaced. For all repairs, insist on only identical National replacement parts.
- 12. REMOVE ALL ADJUSTING KEYS AND WRENCHES:** Make a habit of checking the adjusting keys, wrenches, etc. are removed from the tool before turning it on.

RULES FOR SAFE OPERATION

13. **GUARD AGAINST ELECTRIC SHOCK:** Prevent body contact with grounded surfaces such as pipes, battery plug connection, radiators, ranges and refrigerators. When scoring or making cuts, always check the work area for hidden wires or pipes to reduce shock hazards.
14. **AVOID ACCIDENTAL STARTING:** Be sure equipment is turned off before plugging it in. Do not use if the power switch does not turn the machine on and off properly.
15. **DO NOT FORCE EQUIPMENT:** Equipment will perform best at the rate for which it was designed. Excessive force only causes operator fatigue, increased wear and reduced control.
16. **KEEP HANDS AND FEET AWAY FROM ALL CUTTING EDGES AND MOVING PARTS.**
17. **WEAR GLOVES WHEN CHANGING BLADES.**
18. **DO NOT OVERREACH. MAINTAIN CONTROL:** Stay properly seated. Keep proper footing and balance at all times. Maintain a firm grip.
19. **STAY ALERT:** Watch what you are doing, and use common sense. Do not use when you are tired, distracted or under the influence of drugs, alcohol or any medication causing decreased control.
20. **STARTING MACHINE:** Insure hydraulic levers are “centered” before turning on ignition switch. Throttle should be pushed all the way down.
21. **SHUT-DOWN MODE:** Machine must be in shut-down mode.
22. **MAINTAIN EQUIPMENT CAREFULLY:** Keep control levers dry, clean and free from oil and grease. Keep cutting edges sharp and clean. Follow instructions for lubricating and changing accessories. Periodically inspect battery, charger's and all plug connections. Have damaged parts repaired or replaced.
23. **STORE IDLE EQUIPMENT:** When not in use, store in a dry, secured place. Keep away from children. Remove blade or keep blade lowered to the floor (disarm machine).
24. **MAINTAIN LABELS AND NAME PLATES:** These carry important information. If unreadable or missing, contact National for a free replacement.
25. **MACHINE IS HEAVY, DO NOT DROP:** Counter weights are heavy. Take caution when removing or reassembling. Take caution when moving or transporting.
26. **COMMERCIAL APPLICATION:** Machine is intended for commercial use only.
27. **MACHINE IS EQUIPPED WITH A FIRE EXTINGUISHER:** Be aware of its proximity and how to properly use it.
28. **PROPER VENTILATION: CARBON MONOXIDE IS A VERY TOXIC, COLORLESS AND ODORLESS GAS.** When engines operate in enclosed spaces, such as warehouses, buildings under construction, or tunnels, carbon monoxide can accumulate quickly and reach concentrations that are dangerous for humans. It causes headaches, dizziness, lethargy and death. CO is usually the major concern whenever LPG engines are used indoors

 **WARNING:** Ventilation is required in confined work environments.

 **WARNING:** Exposure to dust may cause respiratory ailments. Use approved NIOSH or OSHA respirators, safety glasses or face shields, gloves and protective clothing. Provide adequate ventilation to eliminate dust, or to maintain dust level below the Threshold Limit Value for nuisance dust as classified by OSHA.

RULES FOR SAFE OPERATION

CHARACTERISTICS OF A DEFENSIVE OPERATOR

- Education
- Alert
- Skills
- Judgment
- Common Sense
- Recognizes the Hazards
- Understands the Defense
- Acts Correctly

A GOOD OPERATOR IS A “DEFENSIVE” OPERATOR

QUALITIES

Education: Learns about the machine and the environment.

Alert: Stays alert at all times...never lets guard down.

Skills: Only performs duties he/she is qualified to do. Always tries to improve.

Judgment: Plays it safe. Doesn't take chances.

Common Sense: Does the right thing without having to be told. Applies knowledge.

Recognizes the Hazards: Maintains alertness. Anticipates danger.

Understands the Defense: Knows that safety isn't an accident...it's a thinking person's choice.

Acts Correctly: Does not cave in to pure pressure. Performs correctly when supervised or not.

USE CARBON MONOXIDE DETECTOR WHEN OPERATING MACHINE

Included with the 5600 are a 75007 Lapel CO Monitor and a 75008 Clip. It is recommended that the operator and anyone in the working vicinity wear the detector. Failure to do so could cause bodily injury and/or death. The use of detectors helps to verify if work area is safe from Carbon Monoxide poisoning. The detector has an adhesive strip on the back for mounting or can be worn with the included clip. It can detect as little as 100ppm (part per million) carbon monoxide gas at approximate relative humidity range of 33 to 50%. If the humidity is very high it can detect concentrations as low as 20ppm. The presence of CO will change the impregnated silica color change from red to red/brown and then to gray/black as the concentration levels increase. Once the detector is exposed to fresh air, it will return back to red. Shelf life in an unopened pack is approximately two to three years (expiration date is visible through unopened package on the back). Once opened it should be replaced approximately every ninety days. Write date opened in provided area on the front of the detector. Read further user directions on the back of the detector.

SAFETY INSTRUCTIONS/ PRECAUTIONS



Read and understand operators instruction manual and instructional video before operating this equipment.



WARNING: Know and understand before operation. Failure to do so could cause damage to equipment or bodily injury.

- Only qualified, trained personnel should operate this unit.
- Loose or damaged parts should be replaced immediately. Failure to do so could cause equipment damage or serious injury.
- Switches and levers should be inspected. (Disconnect battery charger from wall outlet and machine from batteries before repairs to prevent electrical shock). Do not use if defective. Power on/off switch should return to off when lever is released.
- Power control box, motor and switches should be completely enclosed at all times with no exposed wiring.
- Disconnect negative lead before servicing. Failure to do so can cause damage to electrical system and/or electrical shock. 
- Only use National components. Failure to do so could cause damage or serious injury.
- Always be aware of support personnel and their proximity when in operation. Block off work area.
- Support personnel should never stand next to machine, in front of or behind machine while machine is running. Failure to do so could cause serious bodily injury or death.
- Manual should be kept with machine in supplied holder for access by operator at all times.
- Always wear eye protection when running machine.
- Never defeat switches or guards.
- Remove blade when machine is not in use and/or lower cutting head to floor. Failure to do so could cause serious bodily injury.
- Wear gloves when changing blades. Always shut machine off when changing blades.

The 5600 Propane Ride-On should be inspected for damage and defects at least once during every working shift. Starting and stopping procedures must be followed in accordance with the Operating Instructions. Before starting the 5600 Propane Ride-On, be sure that no person is likely to be endangered by the 5600 Propane Ride-On movement.



WARNING: Failure to follow any of the above instructions could cause damage to machine, damage to property or serious bodily injury or death.



WARNING: DANGER-Engine exhaust gases contain poisonous carbon monoxide. Carbon monoxide is odorless and colorless and can cause injury or death if inhaled. Do not use equipment indoors without adequate ventilation. Refer to OSHA guidelines and regulations concerning maximum levels of exposure to carbon monoxide gases and other hazards associated with using internal combustion engines.

SAFETY INSTRUCTIONS/ PRECAUTIONS



Read and understand operators instruction manual and instructional video before operating this equipment.

The 5600 Propane Ride-On has been equipped with a safety switch under the seat, which requires the operator to be seated before the 5600 can be operated. Do not attempt the start-up procedure with out being seated on the machine.



WARNING: Bypassing this or any other safety device may cause property damage and/or bodily injury.

Before carrying out maintenance or repair work:

- Let the engine and the exhaust system, cool down;
- Remove all traces of oil, combustibile fuel or cleaning fluids from the scraper, its connections and fittings in particular;
- Do not use any aggressive cleaning products;
- Be sure that all cleaning rags are fiber free;
- Retighten all loose fittings found during maintenance and repair work.

GASES, DUST, STEAM, SMOKE

Do not weld, flame cut or perform grinding work on the 5600 Propane Ride-On without written authorization from the manufacturer. The danger of fire or explosion exists when work of this nature is done. Begin maintenance work only when the machine is in *Shut Down Mode* (turned off).

SAFETY PRECAUTIONS (OPERATOR/PERSONNEL TRAINING)

Operating and maintenance personnel must verify availability of appropriate fire protection equipment, be properly trained in the use of the equipment and know how to contact the Fire Department or Emergency Medical Service if needed.

BATTERY SAFE OPERATION

⚠ CAUTION - PRECAUTIONS:

- a) Contact with electrolytic acid can cause skin irritation and damage clothing. Wear a protective apron, gloves and goggles when working with batteries. Have plenty of fresh water and soap nearby in case battery acid contacts your skin, clothing, or eyes.
- b) Remove personal metal items such as bracelets, rings, necklaces, and watches when working with batteries. A battery can produce a short circuit current sufficient enough to weld metal objects, causing severe burns.
- c) Never smoke or allow a spark or flame in the vicinity of the batteries. Caution must be taken to reduce the risk of dropping metal tools onto the battery. A spark or short circuit may result in an explosion.

FIRST AID

Immediately flush eyes with cold, fresh water for a minimum of 10 minutes if electrolytic acid comes in contact with eyes. Seek professional medical attention.

VENTILATION

Blocking louvers or air flow perforations of convection or fan cooled battery chargers and/or machine will result in damage to the unit. When installing the unit leave space for air to flow freely through the intake and discharge louvers and/or perforations.

MOTOR SAFE OPERATION

 **CAUTION - PRECAUTIONS:** Before servicing, allow engine to cool down. Failure to do so could cause bodily injury.

CHECK FLUID LEVELS

Check oil & coolant levels before operating.

CHECK FOR LEAKS

Inspect propane gas line for leaks.

TROUBLESHOOTING

Trouble	Possible Cause	Remedy
1. The scraper does not work when the pump is generating pressure	<ul style="list-style-type: none"> a. Severe blockage in wheel drive motor hoses b. Wheel drive motors defective 	<ul style="list-style-type: none"> a. Check hoses for blockage and replace hose if necessary b. Call National Service Center
2. The hoses are worn	<ul style="list-style-type: none"> a. Hoses rubbing on components b. Hose has been exposed to poor environmental conditions 	<ul style="list-style-type: none"> a. Replace and protect the hose b. Replace hose and protect equipment from poor conditions
3. The machine makes an unusually loud hissing or whistling noise	<ul style="list-style-type: none"> a. Fluid is passing over relief valves b. Air in hydraulic circuit 	<ul style="list-style-type: none"> a. If noise is continuous, call a National Service Center b. See Trouble 7 and 9
4. Oil deposits are evident on the inner sides of the driving wheels	<ul style="list-style-type: none"> a. The shaft seals of the wheel motors worn out b. Hose fittings are loose 	<ul style="list-style-type: none"> a. Have the shaft seals replaced by a specialist b. Tighten hose fitting. Replace hose or fitting if necessary
5. The machine has no power with the engine running at 3500 rpm.	<ul style="list-style-type: none"> a. Check valve adjustment b. Check hoses for leaks 	<ul style="list-style-type: none"> a & b. Contact National Service Center immediately Do not operate in this condition!!
6. The scraper does not react when the motion control joystick is actuated	See possible cause 5a and 5b	See remedy 5a and 5b
7. The hydraulic oil is very cloudy. Excessive air in the circuit can cause severe damage to pump. Stop machine and repair immediately!	<ul style="list-style-type: none"> a. Water has entered hydraulic tank b. Oil is contaminated with dirt c. Air has entered the circuit 	<ul style="list-style-type: none"> a. Repair tank if necessary. Drain and clean tank thoroughly. Change oil. b. Drain and clean tank thoroughly. Change oil. c. Contact National Service Center

TROUBLESHOOTING

Trouble	Possible Cause	Remedy
8. Excessive amount of oil on chassis	<ul style="list-style-type: none"> a. Outside oil spilled on chassis b. Loose hose connections c. Loose tank fittings 	<ul style="list-style-type: none"> a. Clean machine thoroughly and see if oil returns b. Check for loose hoses c. Check for loose fittings
9. Hydraulic oil and/or oil foam leaking from oil tank. Excessive air in the circuit can cause severe damage to piston pumps. Stop machine and repair immediately!	<ul style="list-style-type: none"> a. Oil level too high b. Oil level too low c. Vent in return filter blocked d. Air getting into hydraulic circuit 	<ul style="list-style-type: none"> a. Drain tank to correct level b. Fill tank to correct level c. Check for blockage d. Check all suction lines. Tighten all hose connections and fittings
10. Engine dies or cuts out	<ul style="list-style-type: none"> a. Fuel tank is empty b. Oil is low c. Operator not seated properly 	<ul style="list-style-type: none"> a. Change or fill fuel tank b. Fill oil to proper level c. Position on seat correctly
11. Red ignition light stays on	<ul style="list-style-type: none"> a. Oil is Low b. Machine is overheating 	<ul style="list-style-type: none"> a. Fill engine oil to proper level b. Let engine cool. Add coolant to proper level
12. Machine doesn't start	<ul style="list-style-type: none"> a. Machine needs to be primed 	<ul style="list-style-type: none"> a. Press primer button once & restart machine

WARNING: DO NOT work with machine at idle. Doing so will cause damage to machine!

FEATURES/SPECIFICATIONS

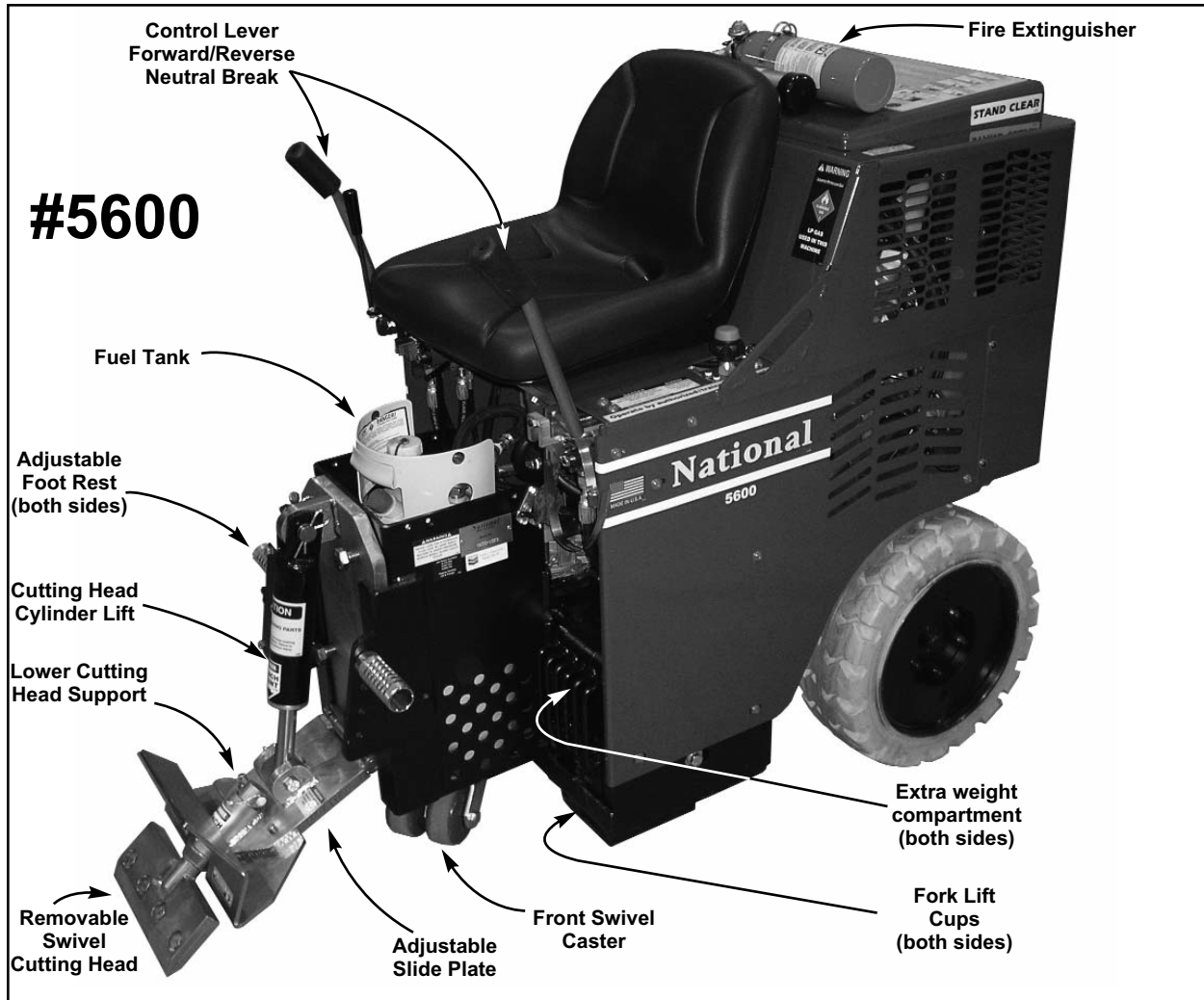

SPECIFICATIONS	#5600
Width:	24½"
Height with Seat:	46"
Length without Jaw:	52"
Weight (machine only):	1116 lbs.
Added Weight:	
Pocket Weight:	464 lbs.
Rear Weight:	83 lbs.
Gross Weight:	1663
Speed:	Up to 150 feet per minute
MOTOR INFORMATION (#5600)	
RPM:	2950
Volts:	12 Volt System
HP:	20
Amps-Full Load:	NA
Continuous Duty:	NA

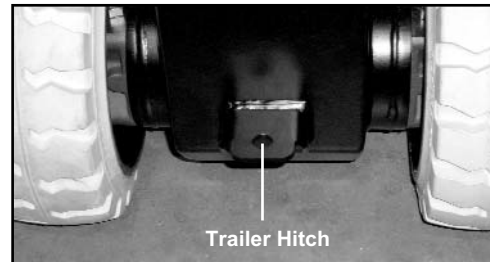

⚠ WARNING: Trailer hitch is only intended to move small trailers on the job site.

FEATURES/SPECIFICATIONS

VIBRATION/SOUND DATA

VIBRATION DATA:

Axis	Stationary	Moving
X	>0.1	0.5
Y	0.3	0.3
Z	0.4	0.1
Vector Sum	>0.1	0.6

Whole Body
Vibration Levels in m/s^2

Axis	Left	Right
X	0.5	1.4
Y	0.3	1.4
Z	0.6	0.5
Vector Sum	0.9	2.0

Hand/Arm
Vibration Levels in m/s^2

SOUND DATA:

	dBA
Stationary	77.0
Moving	73.0

Operator Sound Level
dBA ref. 20 Pa

Emissions meets OSHA standards

OPERATING CONTROLS

START UP PROCEDURE

POWER /Key Start (Figure A)

1. Open propane tank valve by turning knob CCW until fully open.
2. Operator must be seated in seat. The machine will not start unless the operator is seated.
3. Insure that hydraulic levers are “centered”.
4. Set throttle at a quarter open.
5. Start with ignition switch.
6. If machine does not start, press primer button once (in hole on side of machine) (Figure B)
7. Start with ignition switch again.
8. Both a Red & Green light will illuminate (Figure C). As soon as engine starts, the red light will shut off. If the Red light does not shut off, turn machine off.
9. Adjust throttle to move to desired RPM.

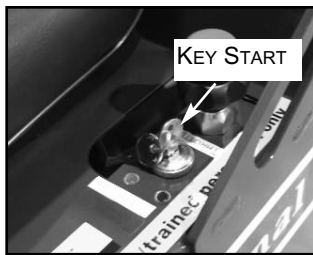

Figure A



Figure B

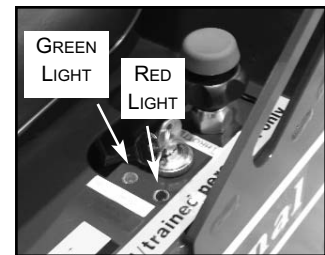

Figure C

⚠ WARNING: DO NOT work with machine at idle. Doing so will cause damage to machine!

⚠ WARNING: Ventilation is required in confined work environments. CARBON MONOXIDE IS A VERY TOXIC, COLORLESS AND ODORLESS GAS. When engines operate in enclosed spaces, such as warehouses, buildings under construction, or tunnels, carbon monoxide can accumulate quickly and reach concentrations that are dangerous for humans. It causes headaches, dizziness, lethargy and death. CO is usually the major concern whenever LPG engines are used indoors

THROTTLE CONTROL (FIGURE D)

- Make sure throttle is pushed down
- Start machine
- Adjust throttle to desired RPM by pulling up on the throttle control
- When at desired RPM, turn throttle friction knob counter-clockwise to hold in position

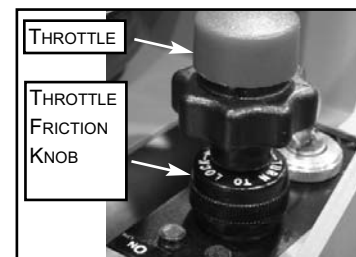

Figure D

HYDRAULIC LEVERS (FIGURE E)

The hydraulic levers steer the machine. They are feathered spool valves. For smooth even movement, always move **levers slowly**. Fast movement on control levers will result in jerky, uneven movement.

(continued on next page)

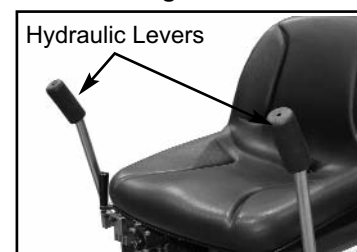

Figure E

OPERATING CONTROLS

HYDRAULIC LEVERS (CONTINUED)

- Move levers slowly.
- Both levers forward **↑↑** move the machine forward.
- Both levers backward **↓↓** move the machine backward.
- The left lever forward and the right lever backward **↑↓** turn the machine quickly to the right.
- The left lever backward and the right lever forward **↓↑** turn the machine quickly to the left.
- Only using the left or right lever forward **↑**, turns the machine slowly to the right or left.
- Only using the left or right lever backwards **↓**, turns the machine slowly to the left or right.
- Correcting direction while moving forward is accomplished by slightly reducing pressure on one lever or the other while moving.
- The center position on levers causes wheels to lock-up.
- Always chock wheels and tie down machine when transporting.

**Control levers are low in vibration.

SEAT SWITCH

The seat has a safety switch. Operator must be properly positioned for machine to run.

CYLINDER LIFT (FIGURE A)

The cylinder lift lever raises and lowers the cylinder and cutting head. After setting slide plate to proper height, use the cylinder lift lever to set blade to proper cutting angle. Pull back **↓** on the cylinder lift lever to raise the cutting head. Push the cylinder lift lever forward **↑** to lower the cutting head. Continuing to push the cylinder lift lever forward and it will adjust the angle of the cutting head. This will also jack up the front of the machine (See Figure B). This will need to be done when doing maintenance on the machine (ie: wheel changing, front caster maintenance etc). When doing machine maintenance, besides raising the cutting head angle, place blocks under the machine (See Figure C). Never use the cutting head only.

⚠ WARNING: Do Not alter a switch or lever. Do Not defeat a safety device.

⚠ WARNING: Disarm machine by removing the cutting head or dropping the cutting head to the floor when the machine is not in use.

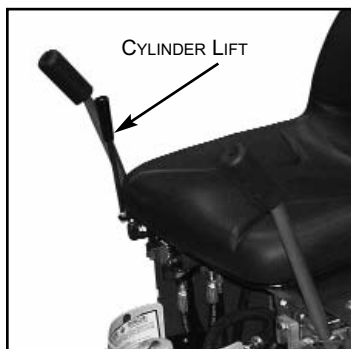

Figure A



Figure B

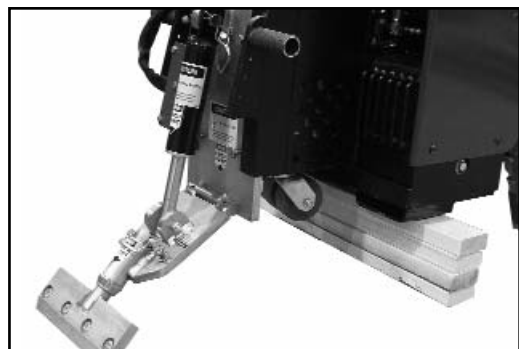

Figure C

OPERATING CONTROLS

NOTE: IF MACHINE IS NOT RUNNING BUT THE KEY IS IN THE IGNITION AND IN ON POSITION, THE HOUR METER WILL CONTINUE TO RUN

SHUT DOWN MODE (SHUT DOWN PROCEDURE/ *TURNED OFF*)

Definition:

State or condition of the 5600 Propane Ride-On that minimizes the danger of mechanical, electrical, pneumatic or hydraulic hazards.

PUTTING THE 5600 PROPANE RIDE-ON IN SHUT DOWN MODE:

- Move the 5600 to level ground
- Turn off the ignition switch and remove the key
- DO NOT move hydraulic levers. The hydraulic system is the brake system. Moving levers could cause machine to roll, causing damage to machine, property damage and/ or bodily injury
- Wait until motor has stopped completely
- Close propane tank valve (Figure A)
- Let the engine, exhaust system and hydraulic components cool down before performing maintenance on the machine

⚠ WARNING: Engine, exhaust system and hydraulic component temperatures could be in excess of 200° F causing severe burns if touched.



Figure A

MACHINE STORAGE

- Follow Shut Down Mode procedure
- After engine has completely cooled down, disconnect propane line
- Remove negative terminal on battery

OPERATING CONTROLS

CHANGING PROPANE TANK

TO CHANGE THE PROPANE TANK:

- Turn machine off
- Shut propane tank off (Figure A)
- Release hood strap
- Remove T-handle bolt (Figure B)
- Release tank bracket (bracket does not need to be removed, it will swing back) (Figure C)
- Disconnect propane hose (Figure D)
- Remove tank and replace
- Follow steps in reverse order

⚠ WARNING: Ventilation is required in confined work environments. CARBON MONOXIDE IS A VERY TOXIC, COLORLESS AND ODORLESS GAS. When engines operate in enclosed spaces, such as warehouses, buildings under construction, or tunnels, carbon monoxide can accumulate quickly and reach concentrations that are dangerous for humans. It causes headaches, dizziness, lethargy and death. CO is usually the major concern whenever LPG engines are used indoors

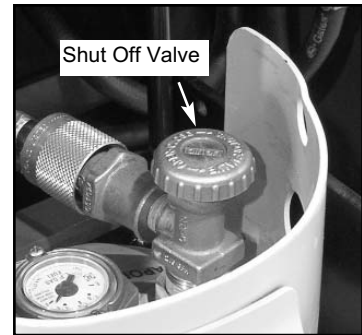

Figure A

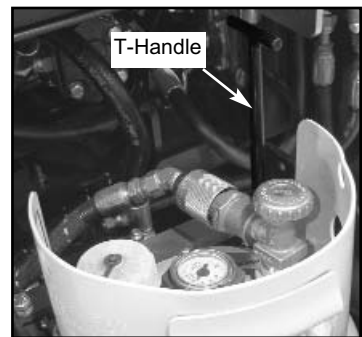

Figure B

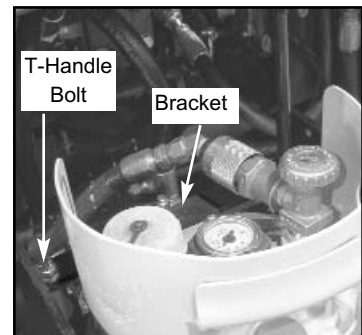

Figure C

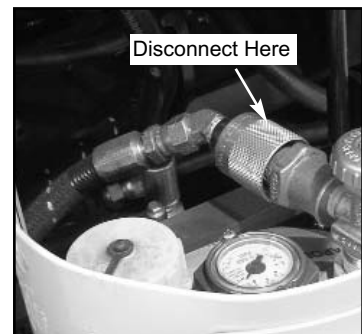

Figure D

CARBON MONOXIDE DETECTOR

Included with the 5600 are a 75007 Lapel CO Monitor and a 75008 Clip. It is recommended that the operator and anyone in the working vicinity wear the detector. Failure to do so could cause bodily injury and/or death. The use of detectors helps to verify if work area is safe from Carbon Monoxide poisoning. The detector has an adhesive strip on the back for mounting or can be worn with the included clip. It can detect as little as 100ppm (part per million) carbon monoxide gas at approximate relative humidity range of 33 to 50%. If the humidity is very high it can detect concentrations as low as 20ppm. The presence of CO will change the impregnated silica color change from red to red/brown and then to gray/black as the concentration levels increase. Once the detector is exposed to fresh air, it will return back to red. Shelf life in an unopened pack is approximately two to three years (expiration date is visible through unopened package on the back). Once opened it should be replaced approximately every ninety days. Write date opened in provided area on the front of the detector. Read further user directions on the back of the detector.

OPERATIONAL TIPS

CASTER

Keep clean and free of debris, make sure it can move freely. Clean as needed. Inspect before each use. Grease once a month.

Moving a "weighted" machine only on the front caster and not on the cutting head or the Front Wheel Assembly can seem to make the machine turn sluggish. It might turn hard to the right or the left. This is normal.

FOOT PEG

Keep feet resting and secured on foot pegs when operating machine. Foot pegs are adjustable. Make sure securing nut is securely tightened

SEAT

Always be properly seated before operating machine. Machine will not run if the operator is not properly seated

DISARM MACHINE

Remove blade or drop cutting head to the floor when machine is not in use.

TURN MACHINE OFF

Never change cutting head or service blade while machine is running.

LEAKAGE

Keep fittings and hoses tight. If a leak is noticeable, retighten fitting. If leakage persists, remove the connection and inspect.

ANGLE OF THE HEAD IS SET STEEP

When raising the front of the machine to a steep angle, the bottom of the slide plate should be raised so it is higher or even with the bottom of the guide channels, 6" to 7" off the floor. This will allow for a steep blade angle without tipping the machine too far back (usually used for re-scrape). The most common mode for take up, is the slide plate is almost to the floor (1/4" to 1/2" from the floor).

RAISING OR LOWERING THE SLIDE PLATE

This will only work without a cutting head inserted in the machine. Completely loosen slide plate bolts. Use cylinder lift lever to raise or lower machine to move slide plate up or down.

 **WARNING:** Always disconnect on board charger before operating machine.

LOADING/UNLOADING

- Always remove blade and cutting head when machine is being moved or transported
- Cutting head and slide plate can be removed to make the machine more compact.
- NEVER leave machine unattended on an incline.
- Removing added weights help to make the machine easier and safer to move in and out of a vehicle.

⚠ WARNING: Machine has a swivel front caster. **Never** side hill (See Figure A). The machine on a incline without power, the front caster will cause machine to swing to the lowest point. If it is necessary to run machine on an incline, run machine on cutting head. Place at least a 8" cutting head in machine. To keep from damaging floor, clamp a piece of carpet into cutting head to slide on the floor. This will give positive contact with the floor when power is disengaged from the wheels.

DOCK HEIGHTS

It is best to load or unload the machine from a level/equal dock height (a van from a van dock height, a truck/semi from a regular dock height).

POWER-GATE

A power-gate can be used when the dock height is not available. Make sure gate is properly rated for 2300 lbs. Make certain the machine is secure so it does not roll off the power-gate. To better secure machine, raise machine onto the lowered cutting head, raising machine off the caster. Tie machine down, chock wheels.

RAMPS

To be safe, the ramp needs to be very long to accommodate the machine being loaded/unloaded. Remove added weight. Make sure ramp is secured. Do not have at a steep incline. The use of a power winch or hand come-a-long is much safer. For a van, the ramp should be 12 to 18 feet in length depending on the depth of the incline. For truck height taller than a van, longer ramps will be needed. See OSHA guidelines. It is not recommended to drive the machine, connected with power, on a ramp. Make sure ramp is secure and has good contact before using. Failure to do so could cause ramp to fall away from the vehicle.

Note: See correct and safe operating angles and center of gravity on page 26.

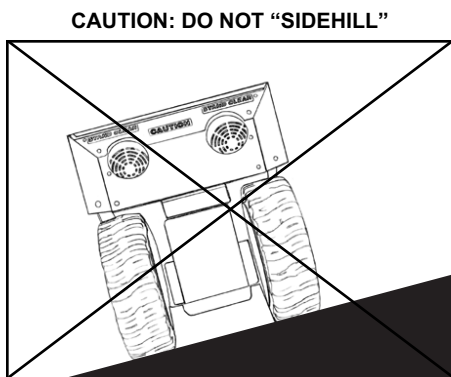
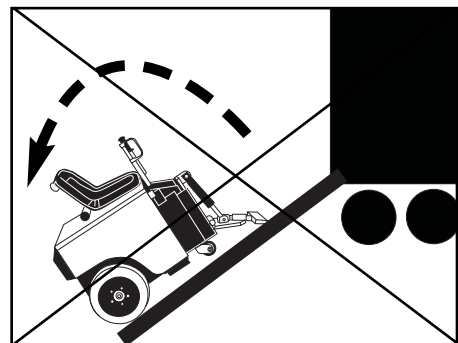

Figure A

CAUTION: MACHINE IS BACK HEAVY.
DO NOT RUN ON STEEP INCLINE--
THIS COULD CAUSE MACHINE TO TIP OVER!



LOADING/UNLOADING

FORKLIFT CUPS

There are two forklift cups mounted under the front of the machine (See Figure A). Slide fork lift forks through forklift cups. Slide forks all the way back to touch the rear tire (See Figure B). Before lifting machine, secure machine to fork lift with heavy 3000 lb. or heavier rope or chain. Tilt forks back to lift machine (See Figure C).

▲ WARNING: Never tilt machine forward. It could slide off fork lift forks.

WINCHES

Winches should be used for safety when loading or unloading with ramps. 2000 lb. winch minimum.

TRANSPORTING

Secure machine down with ratchet straps when transporting the machine. Chock wheels to keep machine from rolling, hydraulic levers should **not** be locked in the forward or backward position. Hydraulic levers should be straight up in the "neutral" position. This helps to lock drive wheels. Lift machine off swivel caster by lowering cutting head for better stabilization. Proper securing straps need to be rated at least twice the weight of the machine.

WHEEL CHOCKS

Wheel chocks will help to secure the machine but DO NOT use wheel chocks alone to secure the machine.

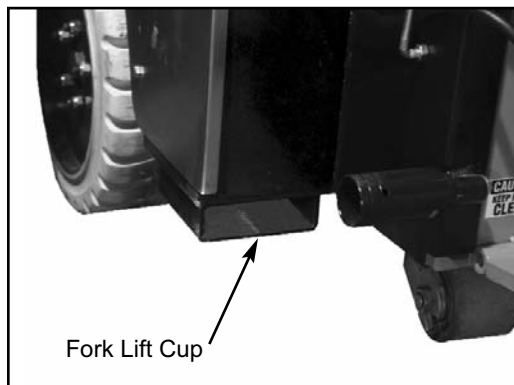

Figure A

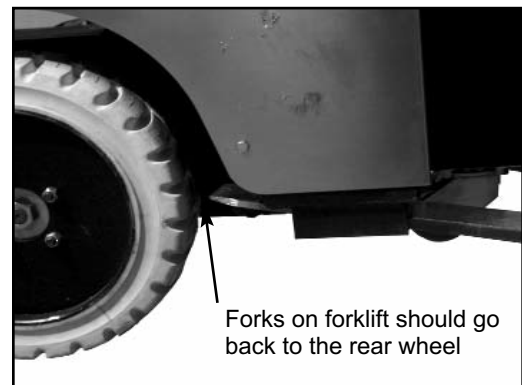

Figure B

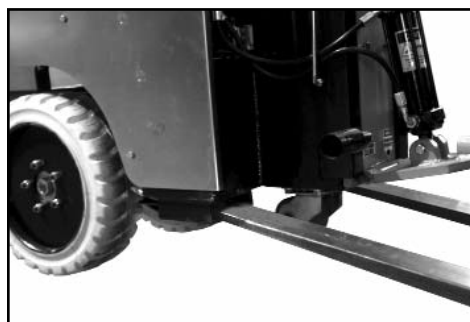
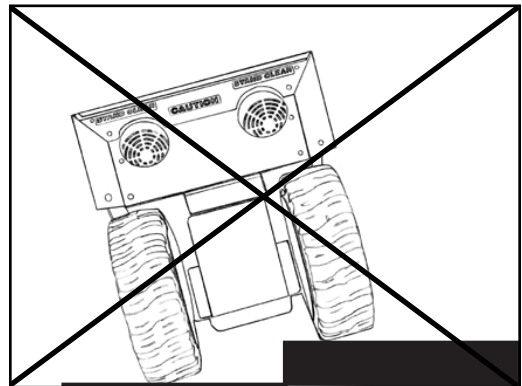
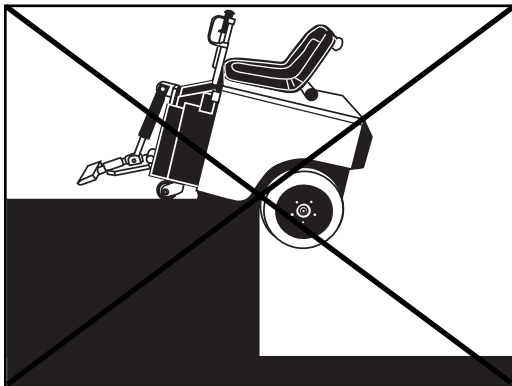
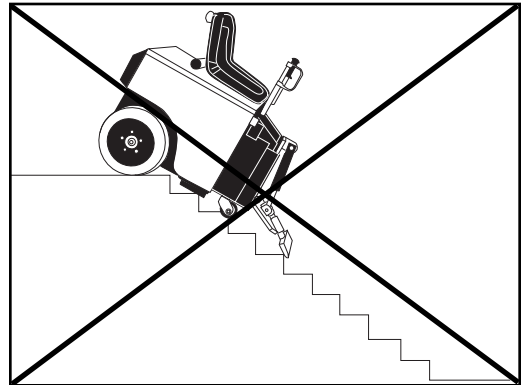
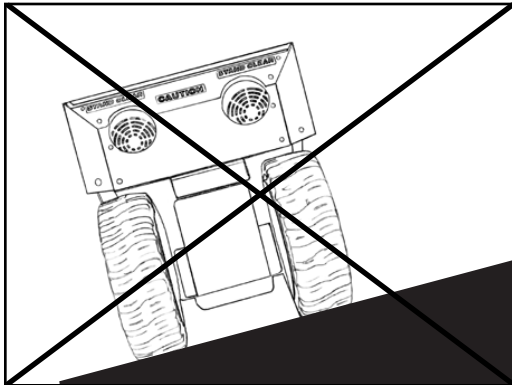

Figure C

CENTER OF GRAVITY

Be aware of your surroundings and machines operating angles. When changing from a low slide plate to a high slide plate setting or a low cutting head angle to a high cutting head angle, the operating “attitude” of the machine changes. When a floor surface is not level (ramps, inclines, large amounts of debris which would lift the drive wheel of the machine, etc.), the center of gravity changes. Too much of an angle could make the machine unsafe (a cause for tip-over). **Do Not** run the machine in unsafe environments.



**CAUTION: MACHINE IS BACK HEAVY.
DO NOT RUN ON STEEP INCLINE--
THIS COULD CAUSE MACHINE TO TIP OVER!**

**CAUTION: MACHINE IS BACK HEAVY.
DO NOT RUN ON STEEP INCLINE--
THIS COULD CAUSE MACHINE TO TIP OVER!**

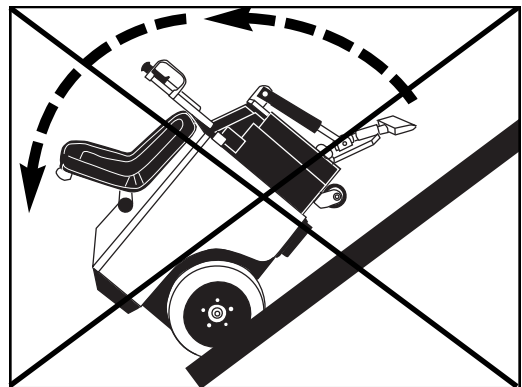
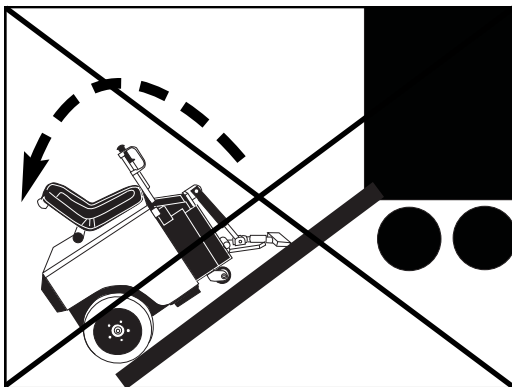

JOB SITE MOVEMENT

- Always remove blade and cutting head when machine is being moved or transported
- Cutting head and slide plate can be removed to make the machine more compact.
- NEVER leave machine unattended on an incline.
- Removing added weights help to make the machine easier to move.

TAPING WHEELS

Taping the wheels with a wide masking tape helps to prevent damage and dirt to floors during move-in and move-out.

LEAP FROGGING BOARDS

Leap frogging boards help to protect floors from damage. Use two or three ¼" luan or plywood sheets, approximately 27" wide by 6' long. Cover one side of the board with a thin a carpet. With the carpet side to the floor, place a board in front of the machine. Drive onto the board. Set the next board in front of the machine. As you drive off one board, pick it up and set it in front of the machine.

PALLETIZING

Only use a solid platform pallet. If a solid platform pallet is not available, place a piece of ¾" plywood on top of a pallet. Using a forklift with the forks inserted in the forklift cups, place machine on pallet. Use ratchet straps to secure machine to pallet.

FRONT WHEEL ASSEMBLY (FIGURE A)

The Front Wheel Assembly is an optional attachment (#5110-100) that is very helpful when moving the machine around on a job-site or loading the machine that is not on a pallet. It allows machine stability and safe transportation over most surfaces. It is easy and quick to attach or detach. Raise slide plate so the bottom of the slide plate is higher or even with the bottom of the guide channels. Raise cylinder, insert Front Wheel Assembly into cutting head. Secure with securing pin.

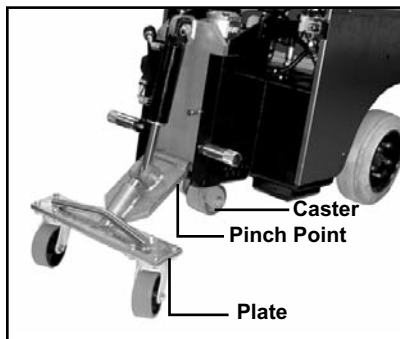

Figure A

Note: Make sure the plate is parallel with the floor so the caster swivels freely.

CAUTION: When moving the slide plate, be aware of pinch point at the bottom of the plate. Failure to do so could cause serious bodily injury.

WARNING: Protect others in work area. Provide barriers or shields as needed to protect others from debris and machine operation. Operator should be aware of who is around them and their proximity.

JOB SITE MOVEMENT

TO MOVE MACHINE WITHOUT POWER (PUSHING MACHINE)

Forward: To move the machine forward, levers need to be pushed forward. To lock levers in place, connect a bungee-strap from each lever (pushing levers forward), pulling straps down to and connecting to the front plate (See Figure A). Never leave machine unattended with strap holding levers open.

Backward: To move machine backward, levers need to be pulled backwards. To lock levers in place, connect a bungee-strap from each lever (pushing levers backward), Pulling straps to the back of the machine and connecting behind the seat or the rear of the machine (See Figure B). Never leave machine unattended with strap holding levers open.

MOVING MACHINE ON CASTER

Moving a "weighted" machine only on the front caster and not on the cutting head or the Front Wheel Assembly can seem to make the machine turn sluggish. It might turn hard to the right or the left. This is normal.

⚠ WARNING: Always remove straps before starting motors. Failure to do so will make machine move and may cause property damage and/or bodily injury.

FORWARD



Figure A

BACKWARD



Figure B

WHEEL SIZES

WHEEL SIZE

The 18" wheel comes standard on the machine. This wheel will work on all job types of application and heavy debris build-up (vct, ceramic etc.). It also works best for slippery/slimy residue, ie. double stick.

Keep wheels clean and free of debris, make sure it can move freely. Clean as needed. Inspect before each use.

To change wheels, see Wheel Changing on page 44.

 **WARNING:** When doing maintenance or changing a wheel, make sure machine is supported properly or serious injury could occur.

CUTTING HEAD & BLADES

DIALING IN THE MACHINE

Dialing in the machine is matching the correct cutting head, blade size, blade angle and added weight to the machine to make the material removal as easy as possible. For every material being removed, there is an optimum blade width, thickness, sharpness, angle and bevel (bevel up or bevel down).

SAVING TIME WITH EXTRA CUTTING HEADS

The machine is supplied with one cutting head. Having additional cutting heads will save time on the job. Insert blades into the extra cutting heads before starting a job. When the blade is dull, instead of taking the time to replace it or sharpen it on the job, take out the cutting head and replace it with another. Or when a different type or size of blade is needed, you have them ready to use.

ADJUSTING SLIDE PLATE AND CUTTING HEAD (FIGURE A & B)

Caution: Pinch point. When adjusting slide plate, keep feet and hands out from underneath the cutting head and slide plate. Failure to do so could cause severe bodily injury. When bolts are removed from the slide plate, the cutting head and the slide plate will drop down to the floor.

- Loosen the two bolts on the front of the slide plate with a 3/4" wrench (See Figure C).
- Slide plate up or down to achieve the desired height of the cutting head.
- Firmly retighten both bolts.

SHEAR POINT

The shear point is the point where material to be removed will cut cleanly from the floor. If the blade is too wide, too dull, or too steep, the shear point is lost.

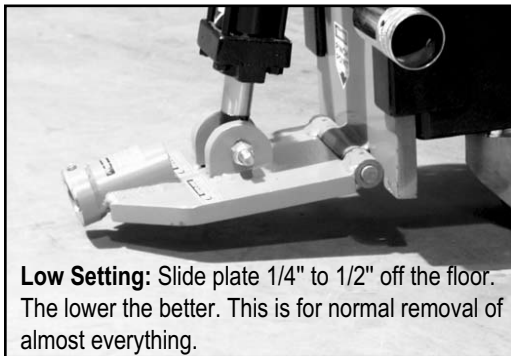

Figure A

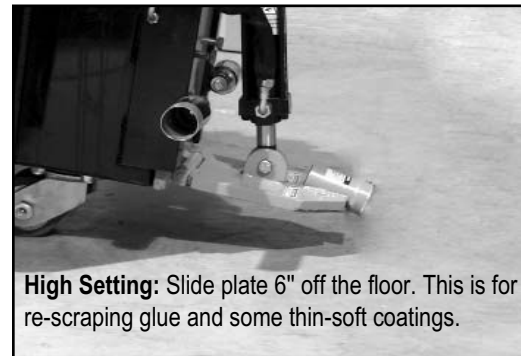

Figure B

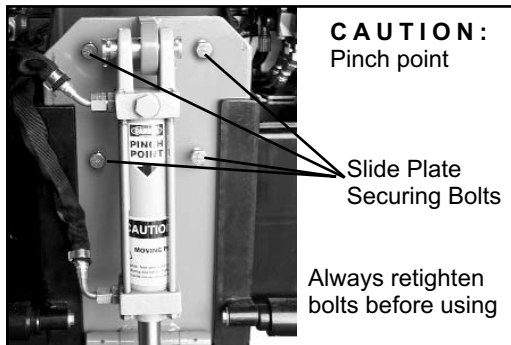

Figure C

CAUTION: Blades are sharp, use extreme caution.

CAUTION: Never change cutting head or service blades while machine is running.

WARNING: Disarm machine when machine is not in use. Remove the cutting head or drop cutting head to the floor. Failure to do so could cause severe bodily injury.

CUTTING HEAD & BLADES

WEIGHT VS. SHARPNESS

The most common way to compensate for a dull blade is to add more weight and raise the blade angle (see re-scrape setting). Weight allows dull blades to be used to a point. Weight also causes blades to dull and break easier. Blades of any thickness tend to catch cracks and expansion joints and will bend or break the blade if set at a high angle. For best results, run a small ditching blade at a low angle to identify as many cracks and joints as possible. If blades are breaking, you are misunderstanding the conditions.

CUTTING HEAD ANGLE

Set the cutting head angle to where the material comes up the easiest. The lowest is usually the best.

STEEP CUTTING HEAD ANGLE

A steep angle is only used for re-scraping. The slide plate has to be raised so the bottom of the slide plate is higher or even with the bottom of the guide channels (See Figure A). Not raising the slide plate when operating the machine at a steep angle will cause the machine to jump and buck. It does not give the operator a clear vision of the cutting head and it raises the machine to operate at a unsafe operating height (See Figure B). Failure to raise the slide plate could cause machine damage and/or bodily injury.

SWIVEL HEAD

The swivel head keeps the blade in contact with the floor even when the floor is uneven. When using a flat blade, by swiveling the head over 180° allows another sharp edge on the blade without having to replace the blade.



Figure A

Correct slide plate setting with a steep cutting head angle.

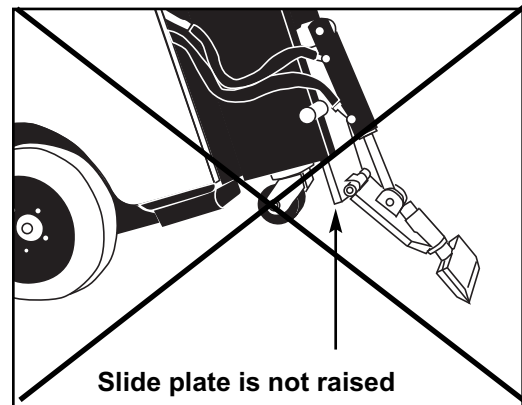

Figure B

Incorrect slide plate setting with a steep cutting head angle.

CUTTING HEAD INSERTION

With machine off, insert desired cutting head into cutting head holder. Secure with cutting head clip.

CAUTION: Watch out for obstructions in the floor (ie. expansion joints, nails, bolts, receptacles). They will break blades.

CUTTING HEAD & BLADES

SHANK BLADE INSERTION

Shank blades do not require a cutting head. Insert desired shank blade into cutting head holder. Secure with cutting head clip.

BLADE SETTING

- Dull blades greatly reduce cutting ability. Re-sharpen or replace as needed.
- Proper blade size and placement, depending on material and sub-floor type, affects performance.
- The harder a job comes up, for best results, use a smaller blade.
- Start with a narrow blade, then increase blade size to optimize cutting pass. Narrower blades work easier than wider blades and usually clean the floor better. Wider is not always better or faster.
- Normally bevel on blade is up for concrete. Bevel down for wood and shoe blades for soft sub-floors.



**BEVEL UP
CONCRETE FLOORS**



**BEVEL DOWN OR
SHOE BLADES
WOOD FLOORS**

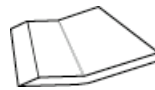

**SHOE BLADE
SOFT SUB-FLOORS**

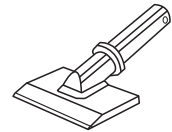

- KEEP BLADES SHARP.
- Dull blades greatly affect the performance of the machine and reduce cutting ability, resharpen or replace as needed.
- Keep your work area clean and clear of debris.
- After you have removed a portion of material, remove it out of the way. This will give the machine maximum performance and help to keep the work area safe.
- Always wear gloves when handling blades.
- Everyone in work area should wear eye protection.

SELF-SCORING BLADES

Instead of pre-scoring a job, for soft goods (carpet, vinyl, linoleum, membrane) the self-scoring blades automatically do the scoring.

BLADE INSERTION OR BLADE CHANGING

Using a 3/4" socket wrench, loosen bolts on cutting head. Quantity of bolts will vary depending upon cutting head size. Insert blade into the cutting head to back of notch (See Figure A). Tighten firmly.

Note: A cordless 3/8" drive impact wrench will speed up this process especially out on the job.

- Sharp blades are imperative for good performance. • Always wear gloves when handling blades.

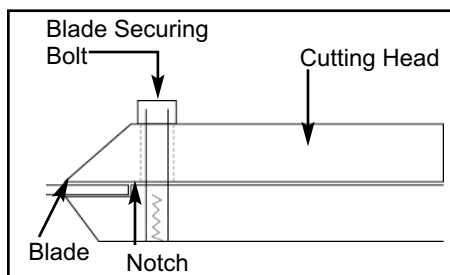

Figure A

CAUTION: Blades are sharp, use extreme caution.

CAUTION: Never change cutting head or service blades while machine is running.

WARNING: Disarm machine when machine is not in use. Remove the cutting head or drop cutting head to the floor. Failure to do so could cause severe bodily injury.

BLADE APPLICATION/SET-UP

CERAMIC SET-UP

Slide plate should be set low, 1/4" to 1/2" off the floor. Use a Shank Blade or a Shank Blade with a carbide tip.

WOOD SET-UP

Slide plate should be set low, 1/4" to 1/2" off the floor. Use Shank Blades, Shank Blades with carbide tips or a 6" or 8" Cutting Head with Shoe Blades, Bent Shoe Blades or Heavy Duty Blades. Note: run machine 45° to the grain of the wood.

SECONDARY BACKING CARPET SET-UP

Slide plate should be set low, 1/4" to 1/2" off the floor. Use a Cutting head from 10" to 27" with Heavy Duty Blades or a Cutting Head from 10" to 14" with a Self-Scoring Blade.

FOAM BACK CARPET SET-UP

Slide plate should be set low, 1/4" to 1/2" off the floor. Use Cutting Heads from 10" to 14" with Self-Scoring Blades. If it is not stuck tight, use a Cutting Head from 14" to 27" with a Standard Blade.

DOUBLE STICK CARPET SET-UP

Slide plate should be set low, 1/4" to 1/2" off the floor. It is best to test to see which is the easiest way to remove double stick. Start with a Cutting Head from 10" to 14" with Self-Scoring Blades. If self-scoring blades do not work, score thru the carpet (See Figure A) the width of the blade (Standard Blade) and scrape up. In some cases, carpet might pull off the pad and then scrape up the pad separately. Usually leaving carpet connected to the pad works the best. Sharp blades are necessary for proper operation.

VCT TILE SET-UP

Slide plate should be set low, 1/4" to 1/2" off the floor. If goods come up easily, change to a larger Cutting Head. If goods come up harder, use a Cutting Head from 6" to 8" with a Premium High Tempered Blade (.062) to match cutting head size. Sometimes a .094 blade may work better. If goods remove easily, a Tile Box #7074 can be used. A tile box also works for wind rowing, assists for a fast clean-up and collection of tile debris for quick removal.

DITCHING (see page 35)

RUBBER TILE SET-UP

Slide plate should be set low, 1/4" to 1/2" off the floor. Use a Cutting Head from 6" to 14" with self-scoring blades or use ditching method with a flat blade (see page 35).

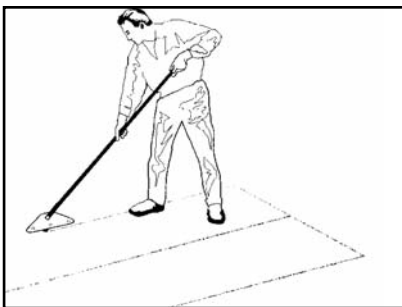

Figure A

CAUTION: Blades are sharp, use extreme caution. 

CAUTION: Never change cutting head or service blades while machine is running.

WARNING: Disarm machine when machine is not in use. Remove the cutting head or drop cutting head to the floor. Failure to do so could cause severe bodily injury.

BLADE APPLICATION/SET-UP

RE-SCRAPING SET-UP

Slide plate should be set high, 6" to 8" off the floor. Use a Cutting Head from 8" to 27" with Scrapper Blades to match cutting head size. A 15" scrapper blade would use a 14" Cutting Head. Razor Blades are faster but a Cutting Head from 8" to 14" can be used with a Standard Blade. Flip head regularly.

THIN COATING SET-UP

Slide plate could be set high, 6" to 8" or low 1/4" to 1/2" off the floor. Test to see which works best. Use a Cutting Head from 8" to 27" with Razor Blades to match cutting head size.

WORKING OVER CONCRETE

Blade should be bevel up when working over concrete. Pretty much anything over concrete works. Try different set-ups to see which works best. If goods come up difficult, slide plate should be at a low setting, 1/4" to 1/2" off the floor. Use a smaller size blade. If goods come up easily, a wider blade can be used.

WORKING OVER WOOD

A heavy machine cannot be used on wood subfloors or raised panel computer floors. Keep machine light, remove all weights. A weighted machine could break through the floor. Slide plate should be set low, 1/4" to 1/2" off the floor. Blades should be as flat of an angle as possible. Use a "shoe blade", Extra Heavy Duty Blade (these blades have a bend to them) or a regular blade, bevel up. When using a regular blade, bending up the corners of the blade will help prevent the blade from digging into the floor. Sometimes a shank blade or a shank blade with a carbide tip will work. Allow blade to shear material from the floor. The trick on wood floors is to run the blade flat. Approach should be at a 45° angle to the board. This keeps from digging into the board and hanging up at the seams.

WORKING OVER SOFT SUB-FLOOR

Slide plate should be set low, 1/4" to 1/2" off the floor. Blades should be as flat of an angle as possible. Use a "shoe blade", Extra Heavy Duty Blade (these blades have a bend to them) or a regular blade, bevel up. When using a regular blade, bending up the corners of the blade will help prevent the blade from digging into the floor. Sometimes a shank blade or a shank blade with a carbide tip will work.

 **CAUTION:** Blades are sharp, use extreme caution.



 **CAUTION:** Never change cutting head or service blades while machine is running.

 **WARNING:** Disarm machine when machine is not in use. Remove the cutting head or drop cutting head to the floor. Failure to do so could cause severe bodily injury.

Note: When removing carpet from over VCT Tile and the tile needs to be saved, run the machine at a 45° angle over the tile. This should help to save the tile.

BLADE APPLICATION/SET-UP

DITCHING

CROSS ROOM DITCHING

When removing hard to remove ceramic, Vct or vat, cross-room ditching will help to make the removal easier. Using a blade 2" to 6" in width, make ditches 1' to 2' apart in the same direction the machine will be removing the goods (See Figure A). This "relieves" the pressure holding the tiles together. If ditching helps and the goods are coming up easy, try using a wider blade to ditch with.

CHECKER BOARD DITCHING

To make carpet removal and debris cleanup easier, checker board ditching is very helpful. Using as wide of a self-scoring blade as possible, make ditches 4' to 6' apart crossways from the way the machine will be removing the goods (See Figure B). Running the machine crossways from the ditches will make smaller pieces of debris to be hauled away. Instead of large gummy rolls of carpet, there are small squares that can be rolled, palletized, put on a dolly or folded with the sticky side in. This makes removing the debris easier and reduces the amount of debris.

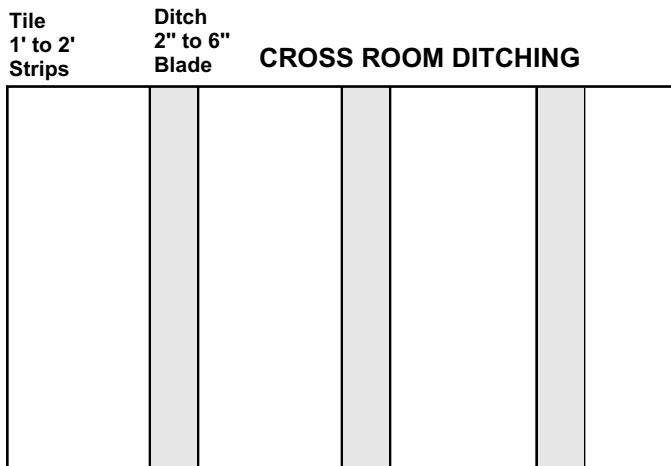

Figure A

↑ Run the machine the same direction that the ditches are made ↑

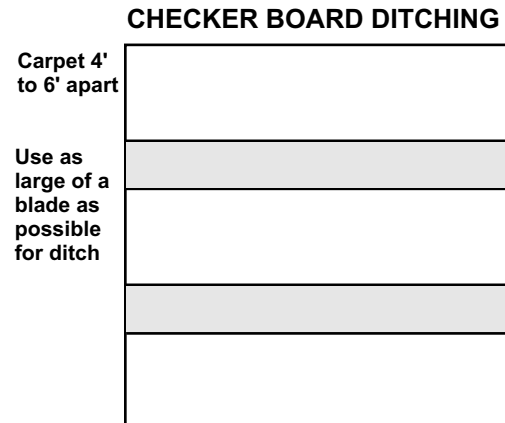

Figure B

↑ Run the machine crossways from the directions that the ditches are made ↑

BLADES

TYPES OF BLADES

PREMIUM HIGH TEMPERED BLADES (.062)

Works on all glued down carpets, VCT, VAT, rubber tile, cork, re-scraping adhesive, elastomeric coatings. Great for floor accumulations. Ultra high quality spring steel is extra hard for long blade life between sharpening.

HEAVY DUTY BLADES (.094)

Works on VCT, VAT, wood, tile, rubber epoxy, thin-set, elastomeric coatings, scraping, thin set and glued ceramic. A heavy-duty blade that still gives a little flex. Blade sharpening process helps these blades to stay sharper longer.

EXTRA HEAVY DUTY BLADES (.187 & .250)

Works on VCT, VAT, wood, tile, thin ceramic, re-scraping thin set, all carpets, cork, elastomeric coatings re-scraping rubber and urethane coatings. Extremely hard, high abrasion alloy for tough tear-up situations. Holds the edge extremely well.

SHOE BLADES/ANGLE SHANK BLADES (.500)

Works well for ceramic, wood, thick epoxy, thin-set, mud set, decorative concrete topping and much more. Blade is mounted at an angle to achieve the optimum shear point for optimum performance. Made from an ultra tough alloy, which is put through special processing to achieve an unbelievable edge holding ability.

SHOE BLADES/ANGLE SHANK BLADES WITH CARBIDE TIPS (.500)

Works well for ceramic, wood, thick epoxy and elastomeric coatings. Carbide tipped for holding a sharp edge for long periods. Nothing else performs like carbide when no other blade will work. Blade is mounted at an angle to achieve the optimum shear point for optimum performance. Made from an ultra tough alloy, which is put through special processing to achieve an unbelievable edge holding ability.

SELF-SCORING BLADES (.062 & .094)

Works on attached cushion, Unitary or secondary backing, vinyl back, soft to medium PVC, linoleum, carpet tiles, soft cork, Enhancer and Unibond hot melts. Instead of pre-scoring a job, the self-scoring blades have "wings" that automatically do the scoring. Blade hardening process makes these blades tough and long lasting.

RAZOR/SCRAPER BLADES (.032 & .045)

Used for re-scraping thin epoxies, thin mil coatings like; urethane paint, poured elastomeric coatings up to 60 mil, hard to remove adhesive and much more.

TILE BOX

Assists for a fast cleanup and collection of tile debris for quick removal. Can be used to remove easy to remove tile. Extremely high abrasion alloy for a long lasting edge. Edge can be re-sharpened.

BLADES

BLADE SHARPENING

Dull blades greatly reduce cutting ability. Re-sharpen or replace as needed. In use, blades develop a back-bevel (See Figure A). When re-sharpening, blade will not be truly sharp until all back-bevel is gone.

Note: Thinner blades are easier to sharpen, but they also break easier.

- Always wear gloves and safety glasses.
- Grind blade using a 4" diameter disk with 120 or finer grit. Be careful not to catch disk on edge or corner of blade.
- Pass grinder back and forth along blade edge being careful to hold grinder at proper angle of blade. Grind until sharp.
- Using a good quality fine tooth hand file, use same procedure as above.
- Blades are sharp. Use extreme caution.
- Have plenty of sharp blades on each job so on-the-job blade sharpening is eliminated.
- It is best to resharpen dull blades on proper bench or belt grinder in the shop, so the blades are ready for the next job.

SELF-SCORING BLADE SHARPENING

It is important to keep the “wings” on a self-scoring blade sharp (See Figure B). Use a file on the “wing” edge. Sharpen the flat part of the blade, the same way as described above.

CARBIDE TIPPED BLADE SHARPENING

To sharpen carbide tipped blades, a wheel to grind carbide is necessary, ie: green wheel or diamond wheel.

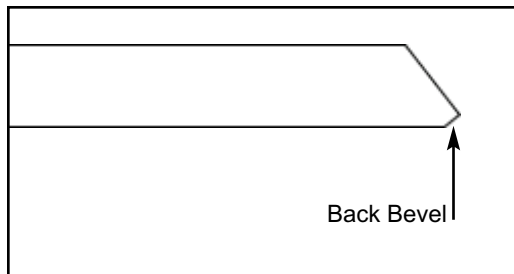

Figure A

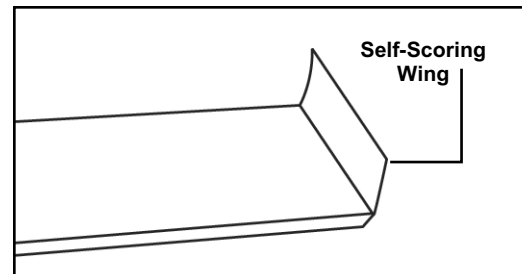

Figure B



CAUTION: Blades are sharp, use extreme caution.



CAUTION: Never change cutting head or service blades while machine is running.



WARNING: Disarm machine when machine is not in use. Remove the cutting head or drop cutting head to the floor. Failure to do so could cause severe bodily injury.

BLADES

Part #	Description	Application	Thickness
#135	5" x 16" Blade	Rubber back carpet on wood or concrete floors, excellent for cleanup and longer durability	.062
#147	4" x 6" Blade	Tile or linoleum on concrete floors	.062
#148	5" x 6" Blade	Tile or linoleum on wood floors	.062
#363-2	3/4" x 8" Razor/Scraper Blade (50/pkg)	Razor sharp, super hard for scraping thin epoxies, thin mil coatings like; urethane paint, poured elastomeric coatings up to 60 mil, hard to remove adhesive and much more.	.032
#368-8	7/8" x 8" Razor/Scraper Blade (50/pkg)		.045
#368-12	7/8" x 12" Razor/Scraper Blade (50/pkg)		.045
#368-15	7/8" x 15" Razor/Scraper Blade (50/pkg)		.045
#6258-BU	3" x 12" Self-Scoring Blade - Bevel Up	Works on attached cushion, Unitary or secondary backing, vinyl backing, soft to medium Pvc, linoleum, carpet tiles, soft cork, Enhancer and Unibond hot melts.	.062
#6259-BU	3" x 14" Self-Scoring Blade - Bevel Up		.062
#6260-BD	3" x 6" Heavy Duty Ditching		.094
#6276-BU	3" x 10" Self-Scoring Blade	Same application as the .062 blade. The 45° angle, self-scoring wings for easy sharpening. The thickness greatly reduces breakage, especially on heavily weighted machines.	.094
#6277-BU	3" x 12" Self-Scoring Blade		.094
#6278-BU	3" x 14" Self-Scoring Blade		.094
#6281	3" x 8" Heavy Duty Blade	A heavy duty blade that still gives a little flex. Made with Nationals proven blade hardening process, these blades will stay sharper longer with better overall performance than any other blade on the market. Works on Vct, Vat, wood, tile, rubber epoxy, thin-set, elastomeric coatings, scraping thin-set, glued ceramic.	.094
#6282	3" x 14" Heavy Duty Blade		.094
#6283	3" x 27" Heavy Duty Blade		.094
#6284	3" x 12" Heavy Duty Blade		.094
#6285	3" x 6" Heavy Duty Blade		.094
#6286	3" x 10" Heavy Duty Blade		.094
#6290	3" x 6" Extra Heavy Duty Blade	Extremely hard, high abrasion alloy for tough tear-up situations. Vct, Vat, wood, tile, thin ceramic, re-scraping thin-set, all carpets, cork, elastomeric coatings, re-scraping rubber and urethane coatings. Holds the edge extremely well.	.187
#6291	3" x 8" Extra Heavy Duty Blade		.187
#6292	3" x 12" Extra Heavy Duty Blade		.187
#6293	3" x 14" Extra Heavy Duty Blade		.187
#6294	3" x 27" Extra Heavy Duty Blade		.187
#7050-200	3" x 6" Premium High Tempered Blade	Ultra high quality spring steel is extra hard for long blade life between sharpening. Works on all glue down carpets, Vct, Vat, rubber tile, cork, re-scraping adhesive, elastomeric coatings. Great for floor accumulations.	.062
#7050-201	3" x 8" Premium High Tempered Blade		.062
#7050-202	3" x 10" Premium High Tempered Blade		.062
#7050-203	3" x 12" Premium High Tempered Blade		.062
#7050-204	3" x 14" Premium High Tempered Blade		.062
#7050-205	3" x 27" Premium High Tempered Blade		.062
#7070-2	4" x 2" Straight Shank Blades	Works well for ceramic and thick epoxy. Made from an ultra tough alloy, which is put through special processing to give these blades unbelievable edge holding ability for ceramic, epoxy, thin-set, mud-set, decorative concrete toppings and much more.	.500
#7070-3	4" x 3" Straight Shank Blades		.500
#7070-4	4" x 4" Straight Shank Blades		.500
#7070-6	4" x 6" Straight Shank Blades	Works well for ceramic and thick epoxy. The same application as the #7070 Blades except mounted at an angle to achieve the optimum shear point for optimum performance.	.500
#7071-2	4" x 2" Angle Shank Blades		.500
#7071-3	4" x 3" Angle Shank Blades		.500
#7071-4	4" x 4" Angle Shank Blades		.500
#7071-6	4" x 6" Angle Shank Blades	Works well for ceramic and thick epoxy. The same application as the #7070, includes the angle like the #7071 and carbide tipped like the #7072. Works well on elastomeric coatings.	.500
#7072-2	4" x 2" Straight Shank w/Carbide Tip		.500
#7072-3	4" x 3" Straight Shank w/Carbide Tip		.500
#7072-4	4" x 4" Straight Shank w/Carbide Tip		.500
#7072-6	4" x 6" Straight Shank w/Carbide Tip		.500

BLADES

Part #	Description	Application	Thickness
#7074	5" x 27" Tile Box with 6" High Box	Extremely high abrasion alloy for a long lasting edge. Box assists for a fast clean-up and collection of tile debris for quick removal.	.187
#7075-8	2" x 8" Tapered Cutting Head Shank	The long taper works great on tough wood floors (glued & nailed). The long length allows the blade to easily slide under tough material. Works well on most ceramics and VCT.	.300
#7075-11	2" x 11" Tapered Cutting Head Shank		.300
#7077-8	3.5" x 8" Tapered Cutting Head Shank		.300
#7077-11	3.5" x 11" Tapered Cutting Head Shank		.300
#7076-8	2" x 8" Tapered w/Carbide Tip	The long taper works great on tough wood floors (glued & nailed). The long length allows the blade to easily slide under tough material. Works well on most ceramics and VCT. Carbide tipped for holding a sharp edge for long periods.	.300
#7076-11	2" x 11" Tapered w/Carbide Tip		.300
#7078-8	3.5" x 8" Tapered w/Carbide Tip		.300
#7078-11	3.5" x 11" Tapered w/Carbide Tip		.300
#7079-2	2" x 6" Ultra HD Ceramic Epoxy Blade	Designed for ceramic removal & thin-set re-scraping. 1/2" of carbide which is twice the carbide of the #7072 series blades. The extra carbide allows for maximum re-sharpening. Strong enough to work on machines up to 3500 lbs.	.500
#7079-4	4" x 6" Ultra HD Ceramic Epoxy Blade		.500
#7079-6	6" x 6" Ultra HD Ceramic Epoxy Blade		.500
#7081	3" x 10" Increased Angle Blade	Mainly used for VCT but can be used on most other applications. Supplies more of an angle when needed. Prevents machine from jumping off material.	.062
#7083	3" x 8" Increased Angle Blade		.062

MACHINE MAINTENANCE

MAINTENANCE AND INSPECTION LIST

Time Interval	Inspection Points/Maintenance
Daily	<ul style="list-style-type: none"> • Check air filter on engine • Check the machine for leaks • Check for hose damage • Check the oil level in the machine • Check the wheel tread for dirt build-up • Be sure seat safety switch “dead-man” is working correctly • Check all safety devices • Check all connectors/couplings
Bi-Monthly	<ul style="list-style-type: none"> • Perform a complete wear check on the machine unit and clean the unit completely • Check that all screw connections are secure
Long storage period (maximum three months)	<ul style="list-style-type: none"> • Contact your National Specialist
50-60 Hours	<ul style="list-style-type: none"> • Replace the engine oil and engine oil filter
Initial change first 50 to 60 hours, then every 150 hours	<ul style="list-style-type: none"> • Replace the machine’s hydraulic return oil filter
Initial change first 500 hours, then every 1000 hours	<ul style="list-style-type: none"> • Replace hydraulic oil and in tank suction strainers

MACHINE MAINTENANCE

SLIDE PLATE

TO REMOVE SLIDE PLATE

1. Disconnect machine from power.
2. Remove slide plate pin. Remove cutting head bolt. Remove cylinder from slide plate. Remove slide plate.

OR

1. Disconnect machine from power.
2. Unplug hydraulic lines from cylinder. A small amount of oil leak out of lines. Cap lines or bleed into a container. Wipe up spillage immediately.
3. With lines removed, loosen slide plate securing bolts. Hold slide plate at the top of the cylinder. Take Caution: slide plate will drop to the floor when slide plate securing bolts are disengaged. Keep hands and feet out from underneath slide plate.
4. Remove slide plate, cylinder and lower cutting head support.

Take Caution: slide plate will drop to the floor when slide plate securing bolts are disengaged. Keep hands and feet out from underneath slide plate, failure to do so could cause severe bodily injury.

RAISING OR LOWERING THE SLIDE PLATE

This will only work without a cutting head inserted in the machine. Completely loosen slide plate bolts. Use cylinder lift lever to raise or lower machine to move slide plate up or down.

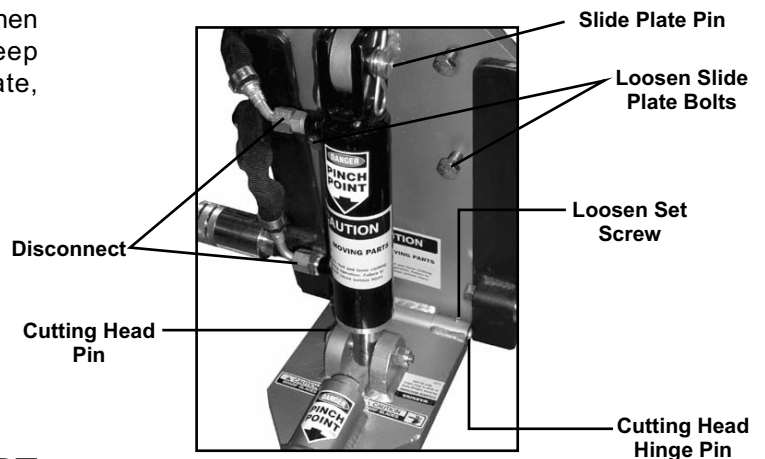

LOWER CUTTING HEAD SUPPORT

To Remove Lower Cutting Head Support

1. Lower slide plate so cutting head hinge pin is below machine bottom. Retighten.
2. Loosen both cutting head pin set screws at the base of the lower cutting head support (hinge area).
3. Drive cutting head pin out using a punch and hammer.
4. Remove cylinder securing hex head bolt.

LEAK MAINTENANCE

All fittings on this machine are O-ring style.

1. Disconnect machine from power.
2. If a leak is detected, tighten fitting with the proper wrench size. DO NOT over tighten. Over tightening could damage O-rings.
3. If a leak still persists, remove fitting and replace O-ring.

MACHINE MAINTENANCE

HYDRAULIC FLUID LEVEL

To Check Hydraulic Fluid

1. Remove Breather Dip Stick (See Figure A)
2. Check to see that Hydraulic Fluid is visible on Dip Stick

OR

1. Remove Filler plug (See Figure B).
2. Oil should be visual 2" below hole.
3. Reinsert plug.

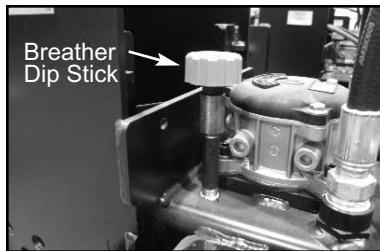

Figure A

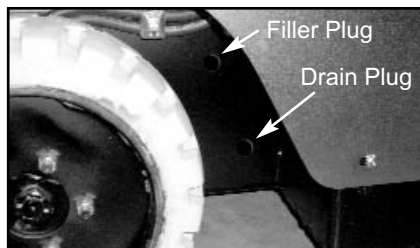

Figure B

HYDRAULIC OIL CHANGE OUT

1. Let Hydraulic fluid cool before maintenance.
2. Disconnect machine from battery.
3. Drain fluid by removing the drain plug from side of tank (See Figure B). **Take Caution:** this unit contains twelve gallons of fluid. Make sure you have the proper amount of containers to catch fluid.
4. Replace drain plug.
5. Remove filler plug (See Figure B).
6. Add oil into the filler plug hole until visual 2" below hole.

HYDRAULIC CYLINDER CHANGE OUT

1. Disconnect machine from power.
2. Disconnect cylinder lines. Have a container ready to catch oil from lines.
3. Remove cylinder securing hexhead bolt from lower cutting head support.
4. Remove clips and pin from cylinder and slide plate.
5. Remove cylinder upper pin.
6. Remove cylinder.

MACHINE MAINTENANCE

ENGINE OIL CHANGE OUT

SEE ENCLOSED **KAWASAKI** MANUAL

To Check engine fluid level, check dip stick on engine (see Figure A). Engine holds 1 quart of oil. Improper fluid level will cause engine damage.

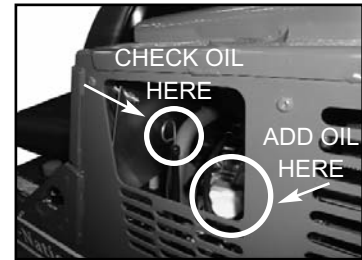

Figure A

ENGINE CHANGE OUT

1. Disconnect motor from power.
2. Lift hood and secure in place.
3. Remove pump (see pump change out).
4. Loosen the bracket holding the motor.
5. Remove engine.

⚠ CAUTION: Let engine cool before any maintenance. Failure to do so could cause serious bodily injury.

HOSE CHANGE OUT

To Remove Or Change A Hose

1. Disconnect machine from power.
2. Remove hood.
3. Using proper wrench size, remove hose from fitting.
4. When replacing, make sure O-ring is properly seated on hose fitting.

FOOT PEG

To Remove Or Replace Foot Peg

1. Insert a socket wrench into foot peg and secure bolt head.
2. Remove nut and washer.
3. Remove bolt and foot peg.
4. Replace foot peg before operating machine. DO NOT use machine without foot pegs.

MACHINE MAINTENANCE

PUMP CHANGE OUT

1. Remove doghouse to expose pump.
2. Disconnect hydraulic lines.
3. Remove two 5/16" pump securing bolts.
4. Remove pump by pulling pump straight out from pump motor.

VALVE CHANGE OUT

1. Disconnect machine from power (charger or battery).
2. Lift hood and secure in place.
3. Remove hoses from valve body. have a container ready to catch leakage from lines.
4. Take notice of angle of valve fittings.
5. Remove two 1/4" bolts securing valve body.



WHEEL MOTOR CHANGE OUT

1. Disconnect machine from power.
2. Block up machine to remove wheel. See wheel changing below.
3. Remove wheel.
4. Remove oil lines from wheel motor. A small amount of oil will run out of the lines. Drain into a container. Wipe up spills immediately.
5. Remove four 1/2" wheel motor securing nuts.
6. Pull out on wheel motor to remove.

WHEEL CHANGING

1. Jack machine up by pushing the cylinder lift forward to lower and adjust the angle of the cutting head to raise machine.
2. Place blocks under Forklift Cups on the side of the machine that wheel is being changed.
Take Caution: Make sure machine is supported properly or serious injury could occur.
3. Let cylinder down resting machine on blocks allowing rear wheel to be lifted off the floor.
4. Remove five 1/2" lug nuts with an extended arm wrench, remove wheel.
5. Replace wheel.

CONTINUED ON PAGE 45

MACHINE MAINTENANCE

WHEEL CHANGING (CONTINUED)

6. Replace five lug nuts and tighten, making sure lug nuts are very tight.
7. Raise cylinder to raise machine off of blocks. Remove blocks and lower machine.
8. Repeat to other side if necessary.

CHANGING HYDRAULIC FLUID FILTER

Filter should be replaced yearly.

NEW STYLE (Figure A)

1. Remove old filter by turning counter-clockwise
2. Install new filter by turning clockwise

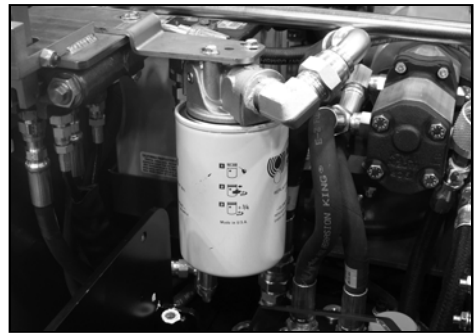

Figure A

CHANGING ENGINE AIR FILTER

SEE ENCLOSED KAWASAKI MANUAL

ENGINE MAINTENANCE

SEE ENCLOSED KAWASAKI MANUAL

⚠ WARNING: Do Not alter a switch or lever. Do Not defeat a safety device.

⚠ WARNING: The Back Up Beeper is on the machine for safety. It is important to keep it in good working condition. Failure to do so could cause bodily injury.

SWITCHES

There are two switches:

1. On (Start) Switch
2. Seat Switch

Do not defeat switches

MACHINE MAINTENANCE

SEAT REPLACEMENT

1. Remove four (4) button hexhead screws on each side of the hood (4 times).
2. Slightly raise seat plate & unplug wire harness.
3. Lift hood off.
4. Remove seat.
5. To replace seat, set seat on top of hood.
6. Replace the four 5/16 button hexhead screws from underneath the hood.
7. Firmly tighten.
8. Reconnect back-up beeper and seat switch wires.
9. Replace hood and screws.

CASTER MAINTENANCE

1. Keep clean and free of debris, make sure it can move freely.
2. Give a shot of grease in grease zerc on caster every six months to keep moving freely.
3. To remove caster, machine will need to be raised. Push the cylinder lift lever forward to lower and adjust the angle of the cutting head to jack up the machine (See Figure A). Block up machine (See Figure B). Remove four bolts, pull caster off, clean/replace as needed.
4. Replace caster.
5. Replace and firmly tighten the four bolts.
6. Lower the machine.

*Note: A spacer is needed with caster when using an 18 inch wheel.



Figure A

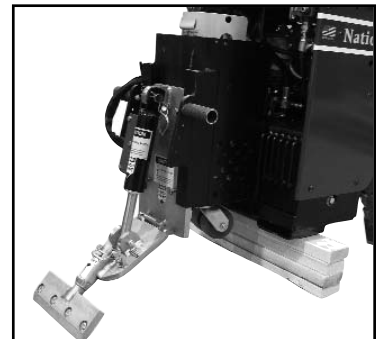

Figure B

MACHINE MAINTENANCE

⚠ WARNING: Always disconnect from battery before maintaining.



⚠ WARNING: Never operate machine without pump guard housing in place.

DEBRIS DEFLECTOR (#5200-258) MOUNTING INSTRUCTIONS

- Insert and secure a cutting head, making sure cutting head is **all the way in**.
- If there are holes on your lower cutting head support**, place debris deflector under the lower cutting head support and bolt in place.
- If there are not holes on the lower cutting head support**, place debris deflector on the lower cutting head support, measuring a 1" clearance between the cutting head and the front of the debris deflector. This clearance will reduce a "pinch point".
- Secure with C-clamps.
- Mark the holes from the debris deflector on the lower cutting head support.
- Either drill a 1/2" hole on each mark and secure debris deflector with a bolt and lock nut **OR** drill a 27/64" hole and tap 1/2-13.
- Firmly secure debris deflector under the cutting head.

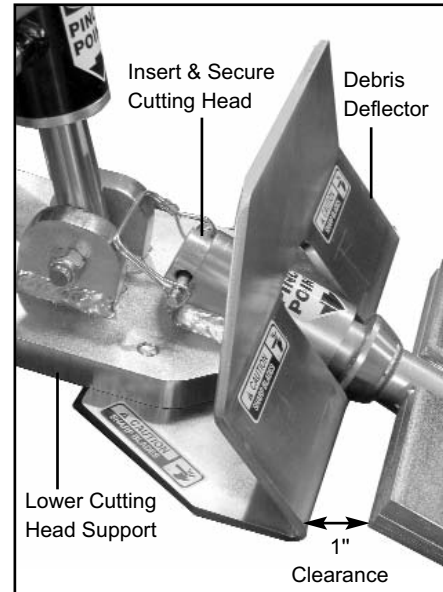

Note: Number in parenthesis () is the amount needed on each machine. Parts are sold individually therefore order the number of parts needed.

COMPLETE PARTS LIST

<u>PART #</u>	<u>DESCRIPTION</u>
5110-111	SEAT
5110-114A	HIGH SPEED HYDRAULIC WHEEL MOTOR (2)
5110-114-2	WHEEL MOTOR FITTING (4)
5110-114-5	WHEEL MOTOR SET OF SEALS (OLD STYLE) (NOT SHOWN)
5110-114-5A	WHEEL MOTOR SET OF SEALS (NEW STYLE) (NOT SHOWN)
5110-115	SINGLE SPOOL CONTROL
5110-115-1	SINGLE SPOOL SEAL KIT (NOT SHOWN)
5110-116	DOUBLE SPOOL CONTROL
5110-116-3	DOUBLE SPOOL SEAL KIT ONLY (NOT SHOWN)
5110-117	WHEEL HUB (2)
5110-117-2	HUB NUT (2)
5110-157	DRAIN/FILLER PLUG (3)
5110-164A	RETURN TANK HOSE
5110-164B	RETURN TANK HOSE CLAMP
5110-166	SLIDE PLATE
5110-167	LOWER CUTTING HEAD SUPPORT
5110-170	CUTTING HEAD PIN
5110-180	FOOT PEG (2)
5110-218	BACK-UP BEEPER SWITCH
5110-233	BREATHER ASSEMBLY
5110-235-1	FILTER HOSE FITTING ONLY (2)
5110-235-2	FILTER "T" ONLY
5110-235-3	FILTER COUPLER ONLY
5110-236-1	REPLACEMENT FILTER RETURN
5110-237	SUCTION FILTER SCREEN (INSIDE HYDRAULIC TANK)
5110-237-1	FILTER SUCTION LINE ASSEMBLY (2)
5110-237-1B	FILTER HOSE FITTING (ONLY)
5110-250	CYLINDER
5110-250-3	CYLINDER SEAL KIT REPLACEMENT
5110-251	CYLINDER CONNECTING ROD
5110-252	CYLINDER CLIP (2)
5110-261-1B	CLAMP BODY ONLY (4)
5110-267	CYLINDER LINE HOSES W/ SHEATH
5110-268	STRAIGHT VALVE FITTING (2)
5110-271	LEVER BRACKET
5110-272	CYLINDER LIFT LEVER ONLY
5110-402	WRENCH SET (NOT SHOWN)
5110-404	WEIGHT, REAR
5200-1G	DOUBLE PUMP GASKET
5200-105	TOOL KIT (NOT SHOWN)
5200-116	BACK-UP BEEPER ASSEMBLY
5200-157	DRAIN/FILLER PLUG (3)
5200-194	DOUBLE WHEEL CASTER ASSEMBLY (GREY)
5200-194A	REPLACEMENT WHEEL ONLY (GREY)
5200-258	DEBRIS DEFLECTOR
5200-261	WHEEL MOTOR LINE (4)
5200-261-1	WHEEL MOTOR HOSE CLAMP ASSEMBLY (2)
5200-266	RETURN LINE (2)
5200-400-2	FRONT WEIGHT INDIVIDUALLY- 36LBS EACH (12)
5200QL-11-LH	SINGLE SPOOL VALVE
5200QL-11-RH	DOUBLE SPOOL VALVE
5200QL-13	VALVE LEVER SPACER
5200QL-14	BACKUP BEEPER PIN ASSEMBLY
5200QL-27	MAIN BASE (NOT SHOWN)
5200QL-31	HOOD LEVER ONLY (NOT SHOWN)
5200QL-32	HOOD LEVER BRACKET ONLY (NOT SHOWN)

COMPLETE PARTS LIST

PARTS LIST (continued)

<u>PART #</u>	<u>DESCRIPTION</u>
5200QL-34	REVERSE CATCH (NOT SHOWN)
5200QL-236	FILTER HOUSING ASSEMBLY (OLD STYLE)
5200QL-236A	FILTER HOUSING GASKET
6280-162G	TANK MAGNET (NOT SHOWN)
5600-13	BATTERY HOLD DOWN
5600-17	MUFFLER BRACKET WELDMENT
5600-21	HANDLE WELDMENT, LEFT
5600-22	HANDLE WELDMENT, RIGHT
5600-25	PROPANE HOLD DOWN BRACKET
5600-30	TOP SHROUD
5600-31	SIDE PANEL, LEFT
5600-32	SIDE PANEL, RIGHT (NOT SHOWN)
5600-34	ENGINE BASE WELDMENT
5600-37	SIDE WEIGHT (NOT SHOWN)
5600-53	REGULATOR BRACKET
5600-54	HOOD LATCH BRACKET
5600-56	PROPANE HOLD DOWN BOLT
5600-57	SAFETY SHUT OFF BRACKET
5600-58	VALVE LEVER - SHORT
5600-59	PROPANE LINE BRACKET
5600-99	KAWASAKI MOTOR
5600-102	CONTROL CABLE (THROTTLE)
5600-103	IGNITION SWITCH
5600-106	MUFFLER TAPE 1"
5600-107	MUFFLER TAPE 2"
5600-108	MUFFLER CLAMP 6"
5600-109	MUFFLER CLAMP 1"
5600-110	LED GREEN
5600-111	LED RED
5600-112	PUMP ADAPTER
5600-116	BATTERY-BLUE TOP
5600-130	CATALYTIC MUFFLER-20 HP
5600-130-1	CATALYTIC MUFFLER-16 HP
5600-300	18" WHEEL RIM & TIRE
5600-VI	INSTRUCTION VIDEO (NOT SHOWN)
5700-36	HOSE GUARD (2)
5700-52	90° VALVE FITTING (2)
5700-54	HANDLE GRIP SLEEVE (2)
5700-55	HANDLE RUBBER COVER (2)
5700-57	FILTER BLOCK
5700-64	FILTER FITTING
5700-65	FILTER
5700-66	HEAD
5700-67	TANK PLUG
5700-70	T-FITTING
5700-72	HOSE (RETURN, LEFT)
5700-75	HOSE (PRESSURE, LEFT-12.5)
5700-76	HOSE (PRESSURE, RIGHT-25)
5700-77	SUCTION LINE (2)
5700-81	PRESSURE LINE (4)
7050-P	PROPANE TANK
70304	REPLACEMENT AIR FILTER (20 HP MOTOR)
70602	INSTRUCTION MANUAL TUBE

COMPLETE PARTS LIST

PARTS LIST (continued)

<u>PART #</u>	<u>DESCRIPTION</u>
70603	INSTRUCTION TUBE CAP
70651	VALVE BODY PLUG (4)
70905-D7	DOUBLE GEAR PUMP
70951	LOVEJOY COUPLER LO 90 DIN, 9T (NOT SHOWN)
70953	SPIDER (NOT SHOWN)
70954	LOVEJOY COUPLER LO 95 X 1½ (NOT SHOWN)
72801	1/4" 90° FITTING (2)
72816	3/8" 90° PUMP FITTING (4)
73008	1/4-20 NYLON LOCK NUT (4)
73020	1/4-20 X 5/8 WIZLOCK BOLT (3)
73021	1/4-20 X 2¼ HEXHEAD CAP SCREW (4)
73047	1/4 X 1 WOODRUFF KEY
73131	3/32 X 1¼ KOTTER PIN (2)
73201	3/8-16 X 1 HEXHEAD CAP SCREW (3)
73202	3/8 INTERNAL WASHER (6)
73203	3/8 SAE FLAT WASHER (2)
73204	3/8 SPLIT LOCK WASHER (2)
73207	3/8-16 NYLON LOCK NUT (2)
73208	3/8-16 X 1½ HEXHEAD CAP SCREW (2)
73212	3/8-16 X 1/2 BUTTON HEAD SOCKET CAP SCREW (17)
73213	3/8-16 X 3/4 BUTTON HEAD CAP SCREW (3)
73227	3/8-24 X 1 SET SCREW (3)
73235	3/8-24 JAMB NUT (3)
73248	5/16-18 X 1/4 CUP POINT SOCKET SET SCREW (2)
73302	5/16 FLAT WASHER, SEAT (4) (NOT SHOWN)
73308	5/16-18 X 3/4 BUTTON HEAD CAP SCREW (2)
73320	5/16-18 X 2 SOCKET HEAD CAP SCREW
73321	5/16-18 X 3½ SOCKET HEAD CAP SCREW
73322	5/16 NYLON LOCK NUT (5)
73324	5/16-18 X 3¼ SOCKET HEAD CAP SCREW, (DOUBLE SPOOL-1, CYLINDER LIFT LEVER-1)
73330	5/16 X 2 LOCK PIN
73333	5/16-18 X 1½ SOCKET HEAD CAP SCREW (3)
73342	5-16-18 X 5 HEXHEAD CAP SCREW (2)
73345	5/16-18 X 1 BUTTON HEAD BOLT, SEAT (4) (NOT SHOWN)
73402	1/2-13 NYLON LOCK NUT (CYLINDER-1, CASTER-4)
73403	1/2 SPLIT LOCK WASHER (WEIGHTS-2, SLIDE PLATE-2)
73406	1/2-13 X 1¼ HEXHEAD CAP SCREW (5)
73408	1/2-13 X 1 HEXHEAD CAP SCREW (2)
73410	1/2-13 X 3½ HEXHEAD BOLT
73414	1/2-13 X 7 HEXHEAD BOLT
73427	1/2-13 X 1½ HEXHEAD BOLT - GRADE 8 (4)
73430	1/2-20 NYLON LOCK NUT (10)
73526	SAE 5/8 FLAT WASHER
73605	3/4-10 X 1½ HEXHEAD BOLT -GRADE 8 (4)
74406	10-32 X 3/8 PHILLIPS PAN HEAD MACHINE SCREW (4)
74425	10/32 K-LOCK NUT (6)
74513	6-32 X 3/4 PHILLIPS PANHEAD MACHINE SCREW (2)
74701	3/4" ID GROMMET (2) (THROTTLE CABLE)
74702	3/8" IC GROMMET (2) (FUEL LINE & WIRE HARNESS)
75005	FIRE EXTINGUISHER
75006	FIRE EXTINGUISHER BRACKET (NOT SHOWN)
75007	LAPEL CARBON MONOXIDE MONITOR
75008	LAPEL CARBON MONOXIDE CLIP
80058	BREATHER W/ 6" DIP STICK

COMPLETE PARTS LIST

BLADES & CUTTING HEADS

<u>PART #</u>	<u>DESCRIPTION</u>
135	5" X 16" BLADE
147	4" X 6" BLADE
148	5" X 6" BLADE
363-2	3/4" X 8" RAZOR/SCRAPER BLADE (50/PKG)
368-8	7/8" X 8" RAZOR/SCRAPER BLADE (50/PKG)
368-12	7/8" X 12" RAZOR/SCRAPER BLADE (50/PKG)
368-15	7/8" X 15" RAZOR/SCRAPER BLADE (50/PKG)
6258-BU	3" X 12" SELF-SCORING BLADE - BEVEL UP
6259-BU	3" X 14" SELF-SCORING BLADE - BEVEL UP
6260-BD	3" X 6" HEAVY DUTY DITCHING
6276-BU	3" X 10" SELF SCORING BLADE
6277-BU	3" X 12" SELF SCORING BLADE
6278-BU	3" X 14" SELF SCORING BLADE
6281	3" X 8" HEAVY DUTY BLADE
6282	3" X 14" HEAVY DUTY BLADE
6283	3" X 27" HEAVY DUTY BLADE
6284	3" X 12" HEAVY DUTY BLADE
6285	3" X 6" HEAVY DUTY BLADE
6286	3" X 10" HEAVY DUTY BLADE
6290	3" X 6" EXTRA HEAVY DUTY BLADE
6291	3" X 8" EXTRA HEAVY DUTY BLADE
6292	3" X 12" EXTRA HEAVY DUTY BLADE
6293	3" X 14" EXTRA HEAVY DUTY BLADE
6294	3" X 27" EXTRA HEAVY DUTY BLADE
7050-6	6" CUTTING HEAD
7050-8	8" CUTTING HEAD
7050-8RBH	8" RAZOR BLADE HEAD
7050-10	10" CUTTING HEAD
7050-12	12" CUTTING HEAD
7050-12RBH	12" RAZOR BLADE HEAD
7050-14	14" CUTTING HEAD
7050-14RBH	14" RAZOR BLADE HEAD
7050-27	27" CUTTING HEAD
7050-200	3" X 6" PREMIUM HIGH TEMPERED BLADE
7050-201	3" X 8" PREMIUM HIGH TEMPERED BLADE
7050-202	3" X 10" PREMIUM HIGH TEMPERED BLADE
7050-203	3" X 12" PREMIUM HIGH TEMPERED BLADE
7050-204	3" X 14" PREMIUM HIGH TEMPERED BLADE
7050-205	3" X 27" PREMIUM HIGH TEMPERED BLADE
7070-2	4" X 2" STRAIGHT SHANK BLADE
7070-3	4" X 3" STRAIGHT SHANK BLADE
7070-4	4" X 4" STRAIGHT SHANK BLADE
7070-6	4" X 6" STRAIGHT SHANK BLADE
7071-2	4" X 2" ANGLE SHANK/SHOE BLADE
7071-3	4" X 3" ANGLE SHANK/SHOE BLADE
7071-4	4" X 4" ANGLE SHANK/SHOE BLADE
7071-6	4" X 6" ANGLE SHANK/SHOE BLADE
7072-2	4" X 2" STRAIGHT SHANK BLADE W/CARBIDE TIP
7072-3	4" X 3" STRAIGHT SHANK BLADE W/CARBIDE TIP
7072-4	4" X 4" STRAIGHT SHANK BLADE W/CARBIDE TIP
7072-6	4" X 6" STRAIGHT SHANK BLADE W/CARBIDE TIP
7074	5" X 27" TILE BOX WITH 6" HIGH BOX
7075-8	2" X 8" TAPERED CUTTING HEAD SHANK
7075-11	2" X 11" TAPERED CUTTING HEAD SHANK
7076-8	2" X 8" TAPERED CUTTING HEAD SHANK W/CARBIDE TIP

COMPLETE PARTS LIST

BLADES & CUTTING HEADS (continued)

<u>PART #</u>	<u>DESCRIPTION</u>
7076-11	2" X 11" TAPERED CUTTING HEAD SHANK W/CARBIDE TIP
7077-8	3.5" X 8" TAPERED CUTTING HEAD SHANK
7077-11	3.5" X 11" TAPERED CUTTING HEAD SHANK
7078-8	3.5" X 8" TAPERED CUTTING HEAD SHANK W/CARBIDE TIP
7078-11	3.5" X 11" TAPERED CUTTING HEAD SHANK W/CARBIDE TIP
7079-2	2" X 6" EXTRA HD CERAMIC EPOXY SHANK W/ CARBIDE TIP
7079-4	4" X 6" EXTRA HD CERAMIC EPOXY SHANK W/ CARBIDE TIP
7079-6	6" X 6" EXTRA HD CERAMIC EPOXY SHANK W/ CARBIDE TIP
7081	3" X 10" INCREASED ANGLE BLADE
7088	3" X 8" INCREASED ANGLE BLADE
73330	5/16 X 2 LOCK PIN

LABELS

<u>PART #</u>	<u>DESCRIPTION</u>
L08-1	STAND CLEAR LABEL (2)
L33B	CAUTION MOVING PARTS LABEL
L33C	INSTRUCTION MANUAL LABEL
L33D	AUTHORIZED PERSONNEL LABEL
L37	CAUTION SHARP BLADES (2)
L66	CAUTION LABEL
L95F	FLUID LEAK LABEL (2)
L98	BLADE LIFT LABEL
L106	PINCH POINT LABEL (3)
L118	OPERATOR MUST BE SEATED LABEL (2)
L137	DISARM MACHINE LABEL (2)
L141	FLAG / MADE IN USA LABEL (2)
L142	TRAILER HITCH LABEL
L165	LARGE RIDE ON LABEL W/ BLADE INFO
L175	NATIONAL LABEL, SMALL
L176	NATIONAL LABEL, LARGE (2)
L223	PATENT NUMBER LABEL
L256	AIR FILTER LABEL (2)
L287	5600 STOCK NUMBER LABEL (2)
L306	SERIAL NUMBER PLATE
L314	LP GAS LABEL
L315	CARBON MONOXIDE LABEL
L316	OIL/TEMP ON LABEL
L317	THROTTLE LABEL
L318	DO NOT TOUCH LABEL
L319	BURN HAZARD LABEL

ACCESSORIES

<u>PART #</u>	<u>DESCRIPTION</u>
5110-100	FRONT WHEEL ASSEMBLY
5110-100W	REPLACEMENT WHEEL ONLY
5110-111-3	OPTIONAL ARM REST/SET - LEFT & RIGHT ARMREST W/ MOUNTING HARDWARE INCLUDED
5600-VI	INSTRUCTION VIDEO
5700-88	HOUR METER
7050-15	CUTTING HEAD EXTENSION
7050-P	PROPANE TANK
7074	TILE BOX
70549	WRENCH
75007	LAPEL CARBON MONOXIDE MONITOR
75008	LAPEL CARBON MONOXIDE CLIP

PART NUMBERS & DIAGRAMS

EXTERNAL PARTS

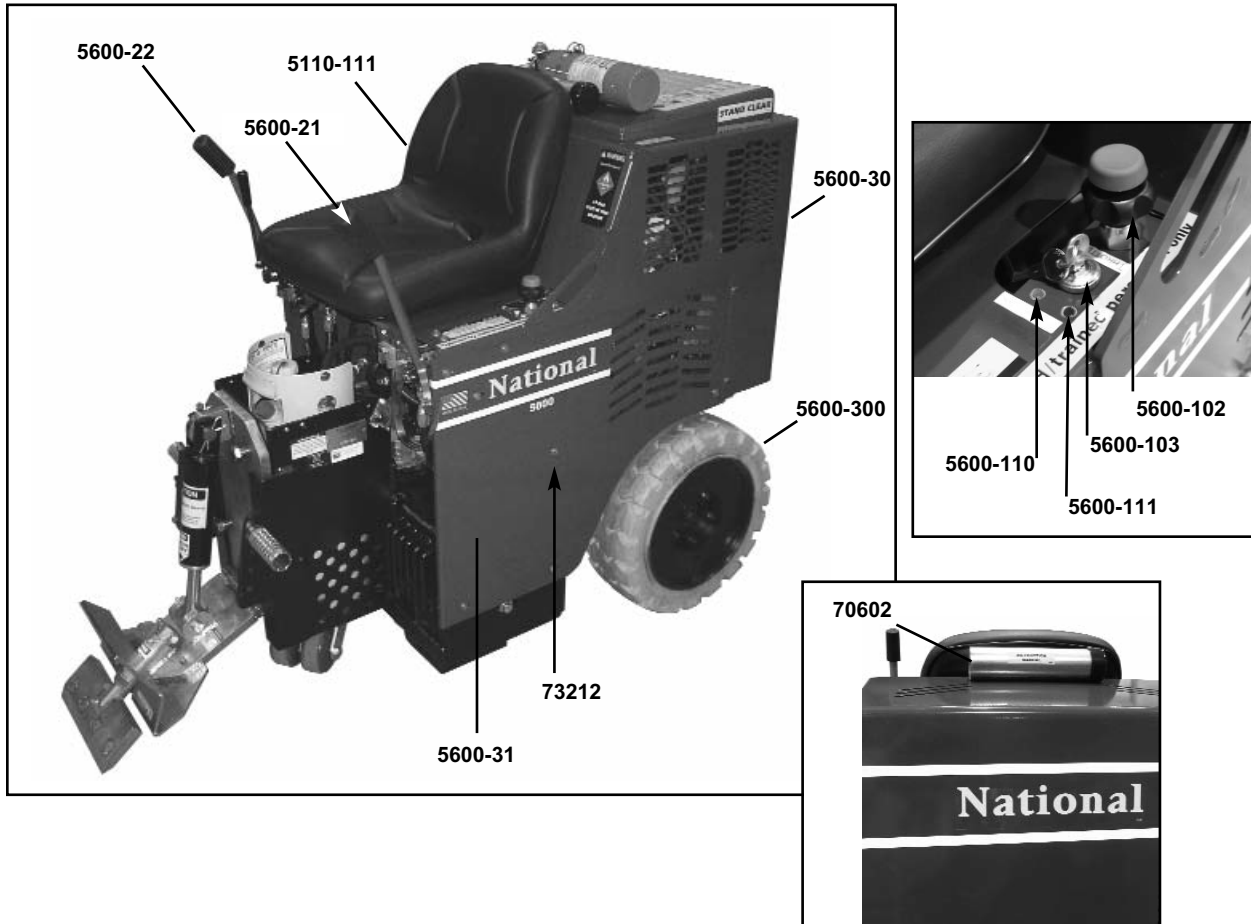

<u>PART #</u>	<u>DESCRIPTION</u>	<u>PART #</u>	<u>DESCRIPTION</u>
5110-111	Seat	5600-102	Control Cable (Throttle)
5600-21	Handle Weldment, Left	5600-103	Ignition Switch
5600-22	Handle Weldment, Right	5600-110	LED Green
5600-30	Top Shroud	5600-111	LED Red
5600-31	Side Panel, Left	5600-300	18" Wheel Rim & Tire
5600-32	Side Panel, Right (Not Shown)	70602	Instruction Manual Tube
5600-37	Side Weight (Not Shown)	73212	3/8-16 x 1/2 Button Head Socket Cap Screw (17)

PART NUMBERS & DIAGRAMS

EXTERNAL PARTS

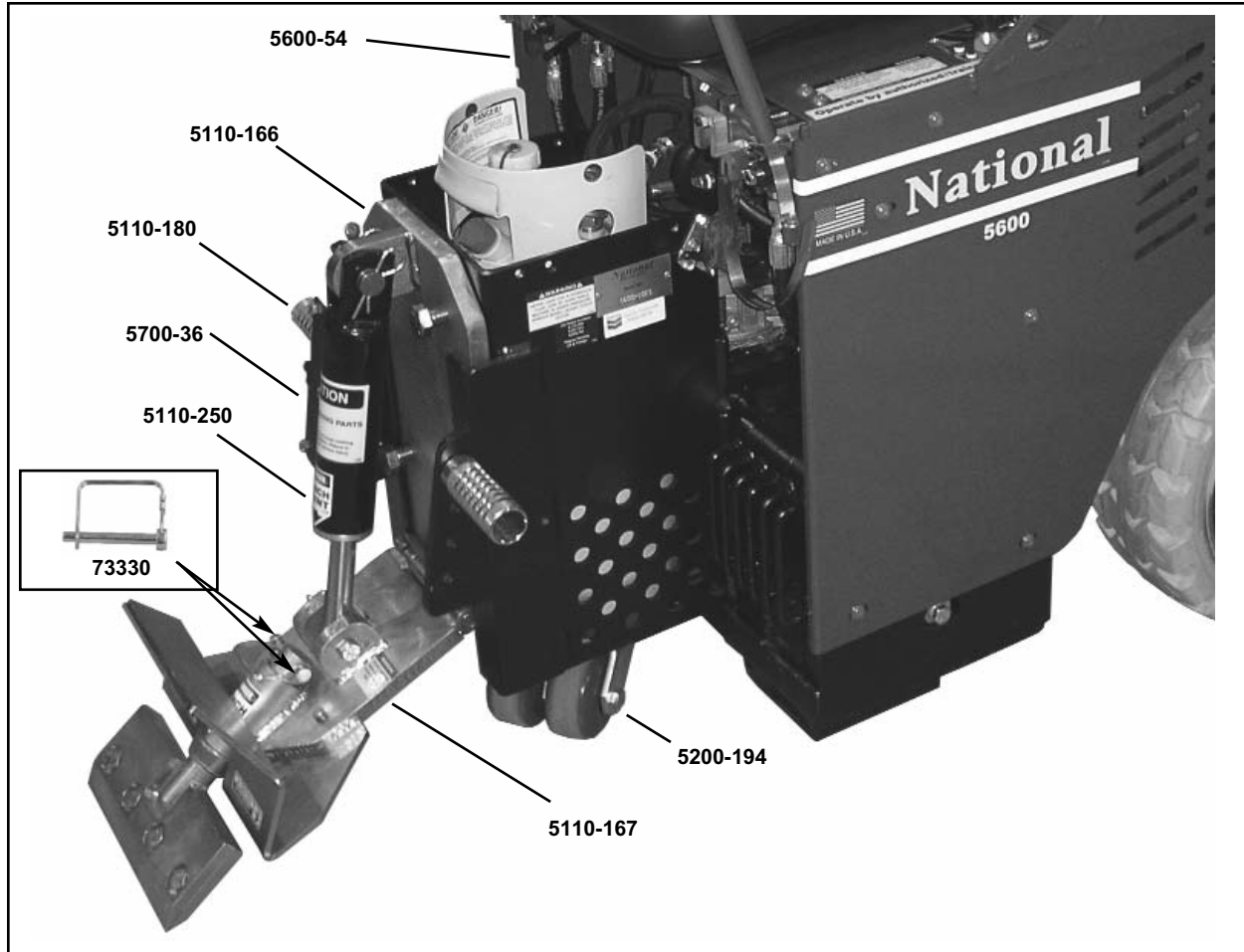

<u>PART #</u>	<u>DESCRIPTION</u>	<u>PART #</u>	<u>DESCRIPTION</u>
5110-166	Slide Plate	5200-194	Double Wheel Caster Assembly (Gray)
5110-167	Lower Cutting Head Support	5600-54	Hood Latch Bracket
5110-180	Foot Peg (2)	5700-36	Hose Guard (2)
5110-250	Cylinder	73330	5/16 x 2 Lock Pin

PART NUMBERS & DIAGRAMS

BEEPER & HOOD PARTS

BACKUP BEEPER ASSEMBLY



PART #

5200-116

DESCRIPTION

Back-Up Beeper Assembly

HANDLE SWITCH (FOR BEEPER)



PART #

5110-218
74513

DESCRIPTION

Back-Up Beeper Switch
6-32 x 3/4 Phillips Panhead
Machine Screw (2)

INSTRUCTION TUBE PARTS

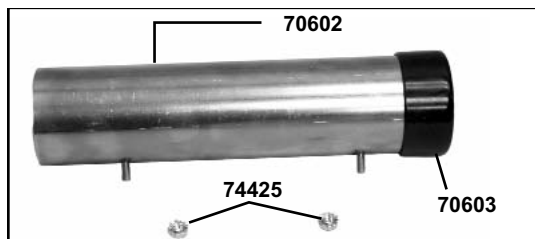

PART #

70602
70603
74425

DESCRIPTION

Instruction Manual Tube
Instruction Tube Cap
10/32 K-Lock Nut (2)

FIRE EXTINGUISHER PARTS

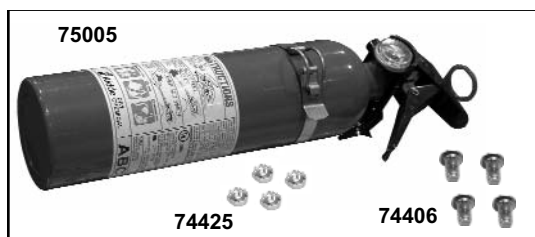

PART #

75005
75006
74406
74425

DESCRIPTION

Fire Extinguisher
Fire Extinguisher Mounting
Bracket (Not Shown)
10-32 x 3/8 Phillips Pan Head
Machine Screw (4)
10-32 K-Lock Nut (4)

PART NUMBERS & DIAGRAMS

GEAR PUMP PARTS



<u>PART #</u>	<u>DESCRIPTION</u>	<u>PART #</u>	<u>DESCRIPTION</u>
5200-1G	Double Pump Gasket	73201	3/8-16 x 1 Hexhead Screw (2)
70905-D7	Double Gear Pump	73203	3/8 SAE Flat Washer (2)
72816	3/8 " 90° Pump Fitting (2)	73204	3/8 Split Lock Washer (2)

PART NUMBERS & DIAGRAMS

WHEEL PARTS

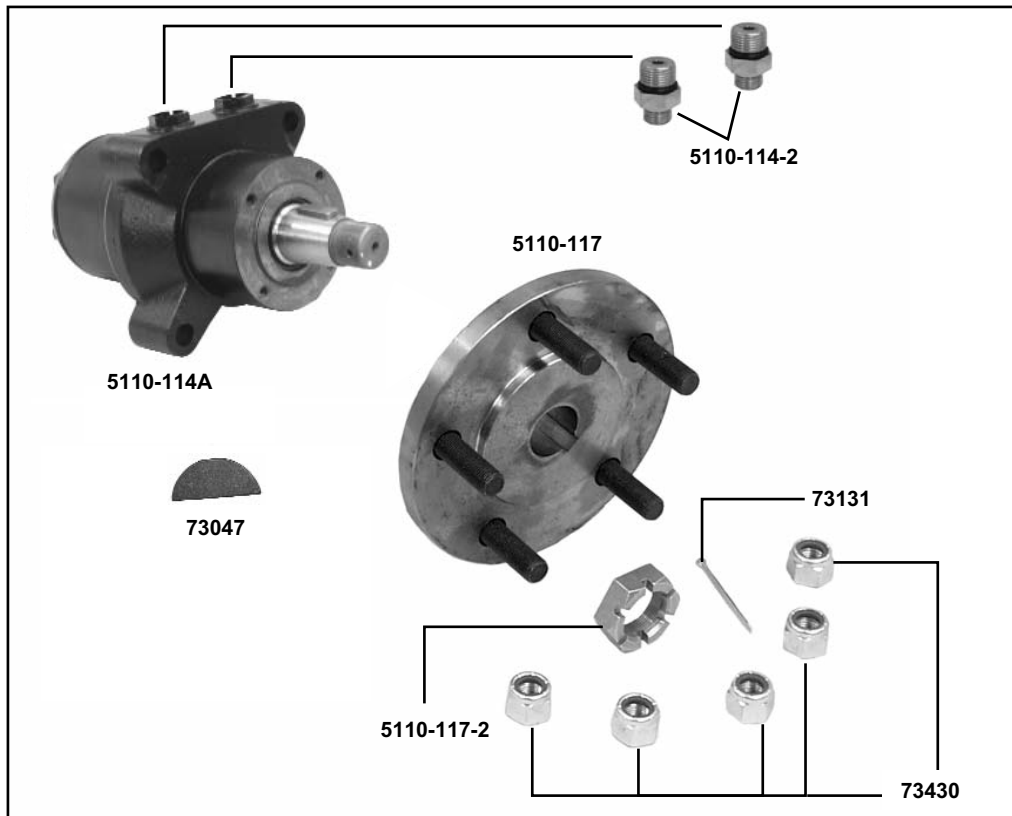

<u>PART #</u>	<u>DESCRIPTION</u>	<u>PART #</u>	<u>DESCRIPTION</u>
5110-114A	High Speed Hyd. Wheel Motor (2)	5110-117-2	Hub Nut (2)
5110-114-2	Wheel Motor Fitting (4)	73047	1/4 x 1 Woodruff Key
5110-114-5	Wheel Motor Set of Seals (Old Style) (Not Shown)	73131	3/32 x 1 3/4 Kottter Pin (2)
5110-114-5A	Wheel Motor Set of Seals (New Style) (Not Shown)	73430	1/2-20 Nylon Lock Nut (10)
5110-117	Wheel Hub (2)		

PART NUMBERS & DIAGRAMS

CONTROL LEVER PARTS (NEW STYLE)

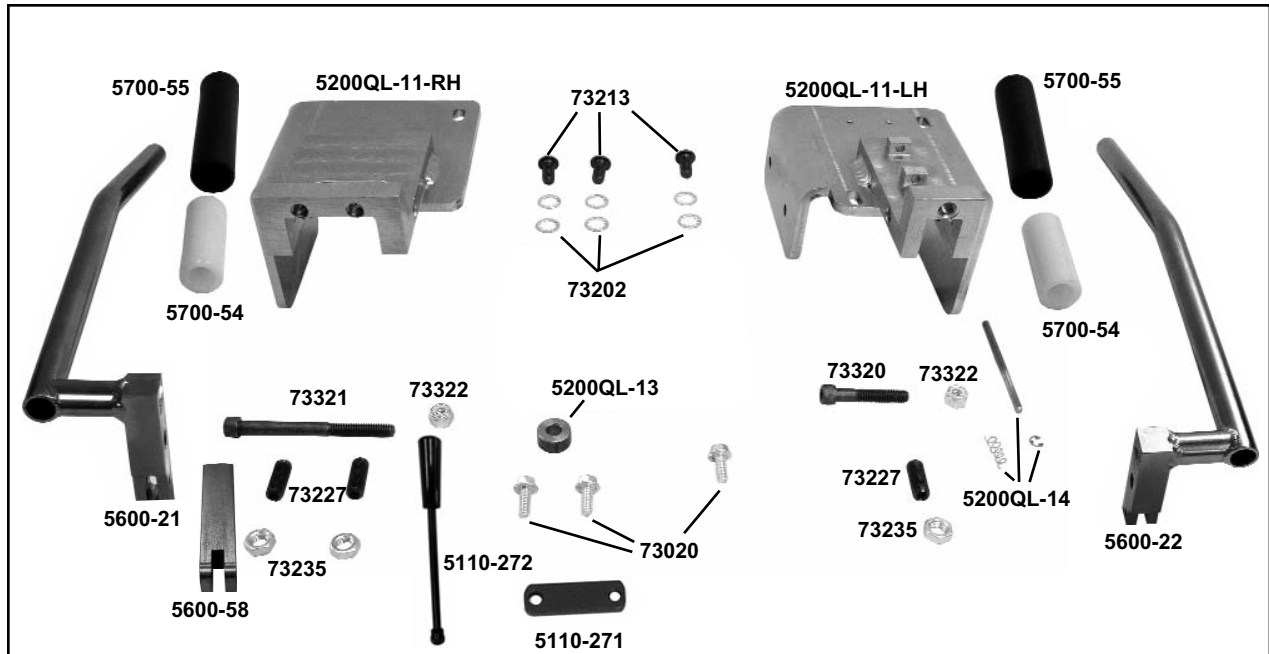

<u>PART #</u>	<u>DESCRIPTION</u>	<u>PART #</u>	<u>DESCRIPTION</u>
5110-271	Lever Bracket	73020	1/4-20 x 5/8 Wizlock Bolt (3)
5110-272	Cylinder Lift Lever Only	73202	3/8 Internal Lock Washer (6)
5200QL-11-LH	Single Spool Valve	73213	3/8-16 x 3/4 Button Head Cap Screw (3)
5200QL-11-RH	Double Spool Valve	73227	3/8-24 x 1 Set Screw (3)
5200QL-13	Valve Lever Spacer	73235	3/8-24 Jamb Nut (3)
5200QL-14	Backup Beeper Pin Assembly	73320	5/16-18 x 2 Socket Head Cap Screw
5600-21	Handle Weldment, Left	73321	5/16-18 x 3 1/2 Socket Head Cap Screw
5600-22	Handle Weldment, Right	73322	5/16 Nylon Lock Nut (2)
5600-58	Valve Lever - Short		
5700-54	Handle Grip Sleeve (2)		
5700-55	Handle Rubber Cover (2)		

PART NUMBERS & DIAGRAMS

SINGLE SPOOL & HOSE PARTS

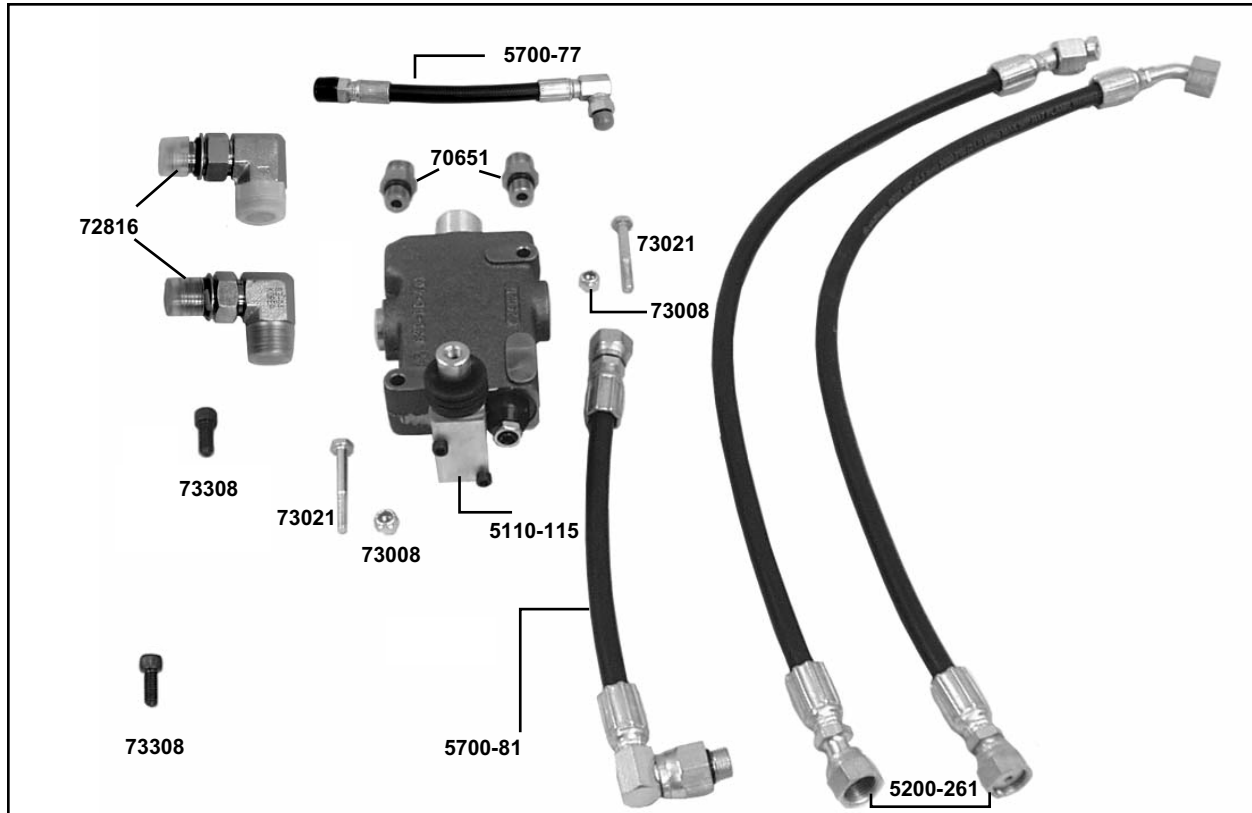

PART #	DESCRIPTION	PART #	DESCRIPTION
5110-115	Single Spool Control	70651	Valve Body Plug (2)
5110-115-1	Single Spool Seal Kit (Not Shown)	72816	3/8" 90° Pump Fitting (2)
5200-261	Wheel Motor Line (2)	73008	1/4-20 Nylon Lock Nut (2)
5700-77	Suction Line (2)	73021	1/4-20 x 2¼ Hexhead Cap Screw (2)
5700-81	Pressure Line (2)	73308	5/16-18 x 3/4 Button Head Cap Screw (2)

PART NUMBERS & DIAGRAMS

DOUBLE SPOOL & HOSE PARTS

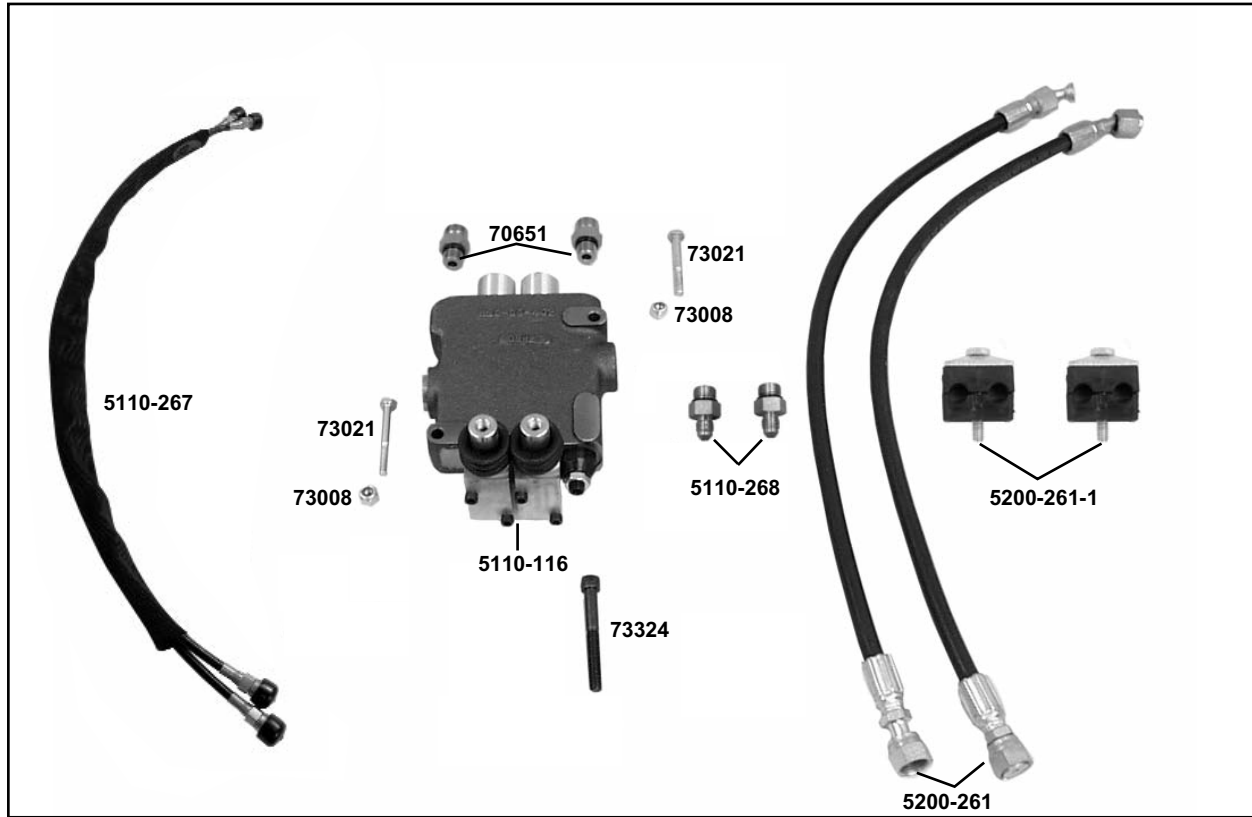

<u>PART #</u>	<u>DESCRIPTION</u>	<u>PART #</u>	<u>DESCRIPTION</u>
5110-116	Double Spool Control	5200-261-1	Wheel Motor Hose Clamp Assm (2)
5110-116-3	Double Spool Seal Kit Only (Not Shown)	73008	1/4-20 Nylon Lock Nut (2)
5110-267	Cylinder Line Hoses w/ Sheath	73021	1/4-20 x 2 1/4 Hexhead Cap Screw (2)
5110-268	Straight Valve Fitting (2)	73324	5/16-18 x 3 1/4 Socket Head Cap Screw
5200-261	Wheel Motor Line (2)	70651	Valve Body Plug (2)

PART NUMBERS & DIAGRAMS

FILTER & TANK PARTS



<u>PART #</u>	<u>DESCRIPTION</u>	<u>PART #</u>	<u>DESCRIPTION</u>	<u>PART #</u>	<u>DESCRIPTION</u>
5110-164A	Return Tank Hose	5110-237-1	Filter Suction Line Assembly (2)	5700-66	Head
5110-164B	Return Tank Hose Clamp	5110-237-1B	Filter Hose Fitting(Only)	5700-67	Tank Plug
5110-233	Breather Assembly	5200-157	Drain/Filler Plug (3)	5700-70	T-Fitting
5110-235-1	Filter Hose Fitting Only (2) - OS	5200-266	Return Line (2)	5700-72	Hose (Return, Left)
5110-235-2	Filter "T" Only - OS	5200QL-236	Filter Housing Assmy - OS	5700-75	Hose (Pressure, Left-12.5)
5110-235-3	Filter Coupler Only - OS	5200QL-236A	Filter Housing Gasket - OS	5700-76	Hose (Pressure, Right-25)
5110-236-1	Replacement Filter Return - OS	5700-57	Filter Block	6280-162G	Tank Magnet (Not Shown)
5110-237	Suction Filter Screen (Inside Hydraulic Tank)	5700-64	Filter Fitting	80058	Breather w/ 6" Dip Stick
		5700-65	Filter		Note: OS=Old Style

PART NUMBERS & DIAGRAMS

CYLINDER PARTS

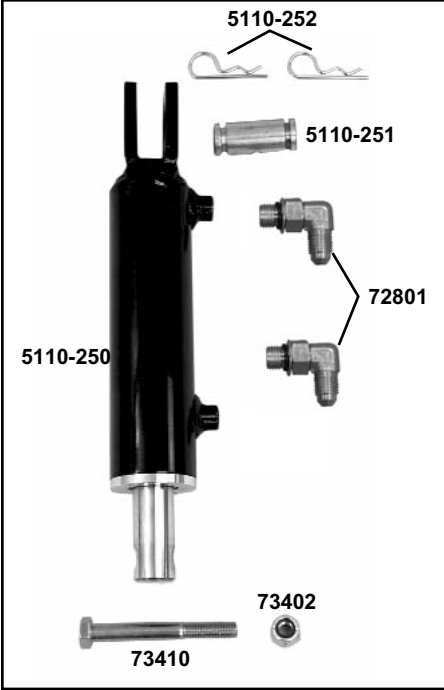

<u>PART #</u>	<u>DESCRIPTION</u>
5110-250	Cylinder
5110-251	Cylinder Connecting Rod
5110-252	Cylinder Clip (2)
72801	1/4" 90° Fitting (2)
73402	1/2-13 Nylon Lock Nut
73410	1/2-13 x 3 1/2 Hexhead Bolt

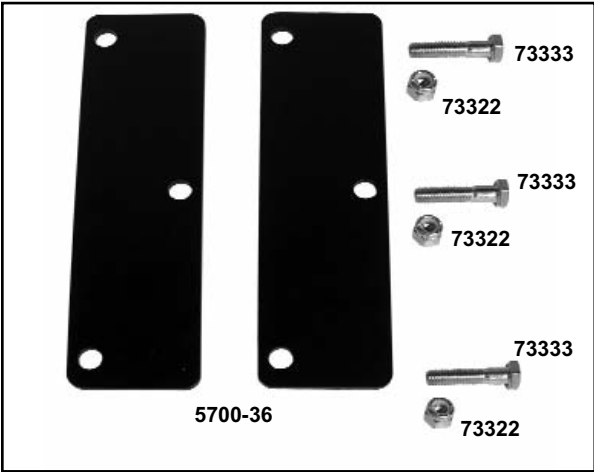

<u>PART #</u>	<u>DESCRIPTION</u>
5700-36	Hose Guard (2)
73322	5/16-18 Nylon Lock Nut (3)
73333	5/16-18 x 1 1/2 Socket Head Cap Screw (3)



<u>PART #</u>	<u>DESCRIPTION</u>
5110-250-3	Cylinder Seal Kit Replacement

PART NUMBERS & DIAGRAMS

SLIDE PLATE/DEFLECTOR, CASTER & FOOT PEG PARTS

SLIDE PLATE

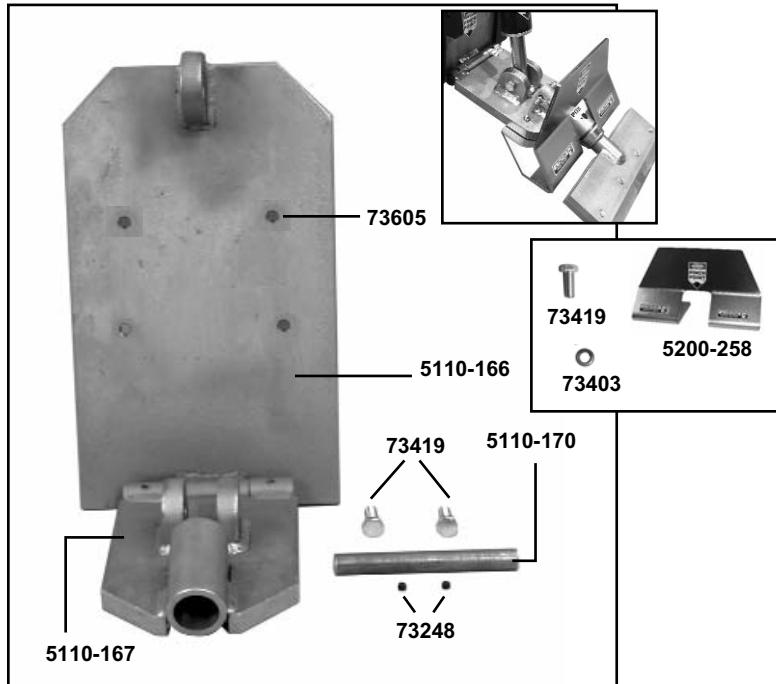

<u>PART #</u>	<u>DESCRIPTION</u>
5110-166	Slide Plate
5110-167	Lower Cutting Head Support
5110-170	Cutting Head Pin
5200-258	Debris Deflector
73248	5/16-18 x 1/4 Cup Point Socket Set Screw (2)
73403	1/2 Split Lock Washer (2)
73419	1/2-13 x 1 1/2 Hexhead Cap Screw, Gr. 8 (4)
73605	3/4-10 x 1 1/2 Hexhead Bolt - Grade 8 (4)

CASTER

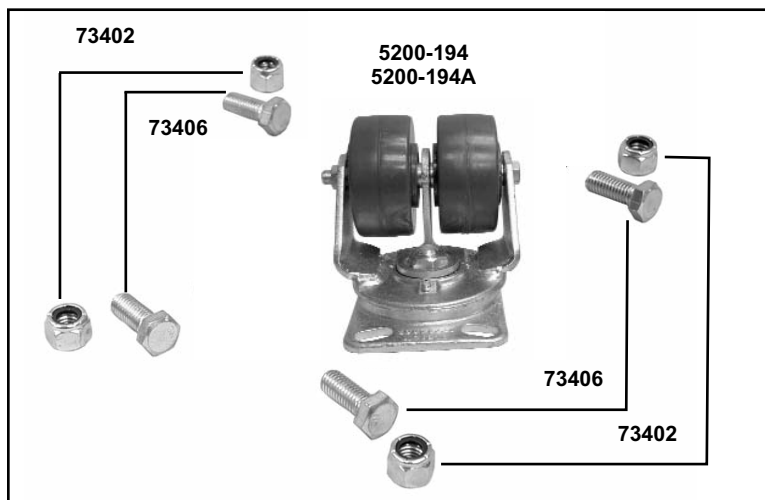

<u>PART #</u>	<u>DESCRIPTION</u>
5200-194	Double Wheel Caster Assembly (Grey)
5200-194A	Replacement Wheel Only (Grey) (2)
73402	1/2-13 Nylon Lock Nut (4)
73406	1/2-13 x 1 1/4 Hexhead Cap Screw (4)

FOOT PEG

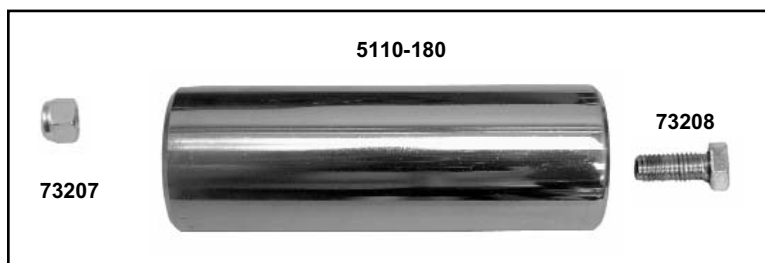

<u>PART #</u>	<u>DESCRIPTION</u>
5110-180	Foot Peg (2)
73207	3/8-16 Nylon Lock Nut (2)
73208	3/8-16 x 1 1/2 Hexhead Cap Screw (2)

PART NUMBERS & DIAGRAMS

PROPANE TANK PARTS

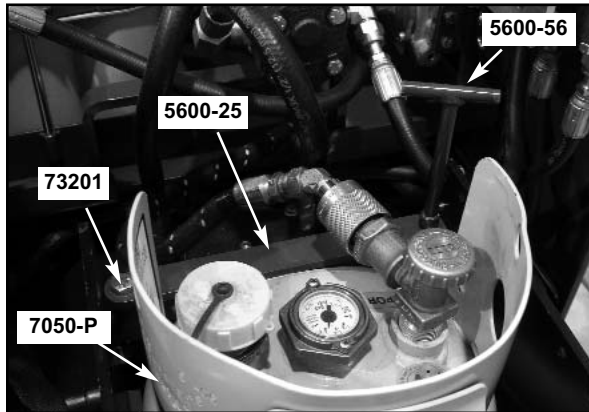

<u>PART #</u>	<u>DESCRIPTION</u>
5600-25	Propane Tank Hold Down Bracket
5600-56	Propane Hold Down Bolt
7050-P	Propane Tank (2 - One in machine & one spare)
73201	3/8-16 x 1 Hexhead Cap Screw

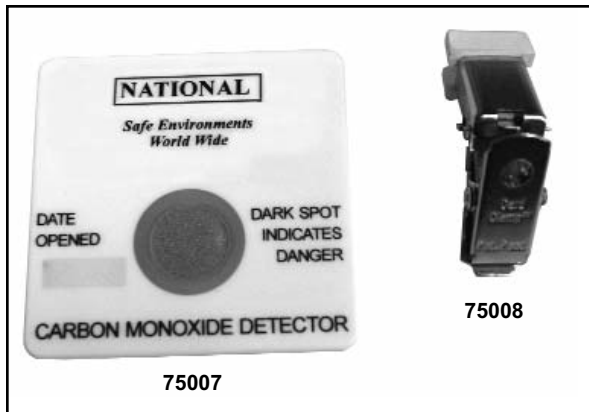

<u>PART #</u>	<u>DESCRIPTION</u>
75007	Lapel Carbon Monoxide Monitor
75008	Label Carbon Monoxide Clip

PART NUMBERS & DIAGRAMS

ENGINE BATTERY

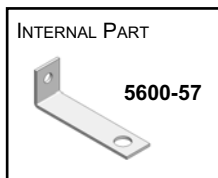
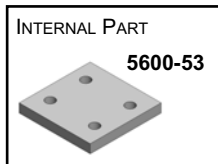
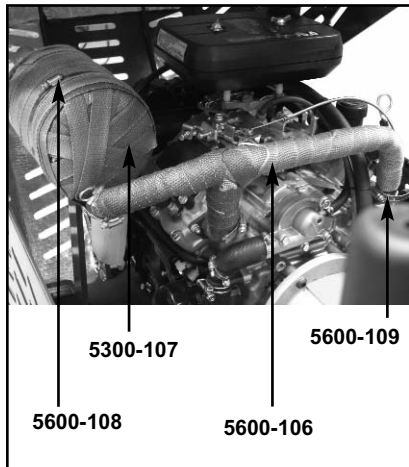
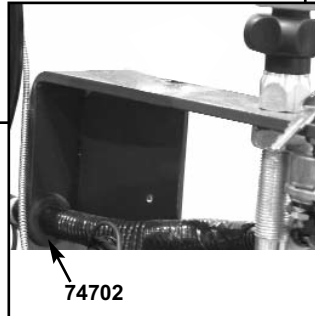
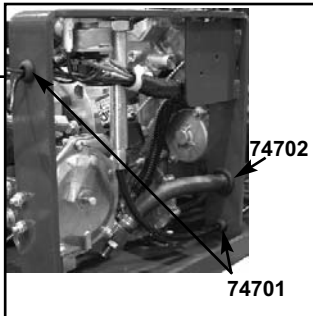
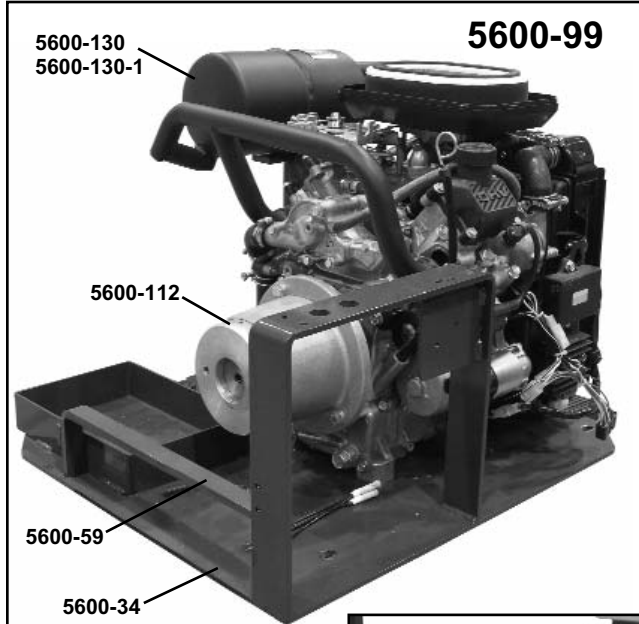

PART #	DESCRIPTION
5200QL-27	Main Base (Not Shown)
5200QL-31	Hood Lever Only (Not Shown)
5200QL-32	Hood Lever Bracket Only (Not Shown)
5200QL-34	Reverse Catch (Not Shown)
5600-17	Muffler Bracket Weldment (Not Shown)
5600-34	Engine Base Weldment
5600-53	Regulator Bracket
5600-57	Safety Shut Off Bracket
5600-59	Propane Line Bracket
5600-99	Kawasaki Motor
5600-130	Catalytic Muffler-20 HP
5600-106	Muffler Tape 1"
5600-107	Muffler Tape 2"
5600-108	Muffler Clamp 6"
5600-109	Muffler Clamp 1"
5600-112	Pump Adapter
5600-130	Catalytic Muffler-20 HP
5600-130-1	Catalytic Muffler-16 HP
70304	Replacement Air Filter (20 H Motor) (Not Shown)
70951	Lovejoy Coupler LO 90 DIN, 9T (Not Shown)
70953	Spider (Not Shown)
70954	Lovejoy Coupler LO 95 x 1¼ (Not Shown)
74701	3/4" ID Grommet (2)
74702	3/8" IC Grommet (2)

PART NUMBERS & DIAGRAMS

BATTERY

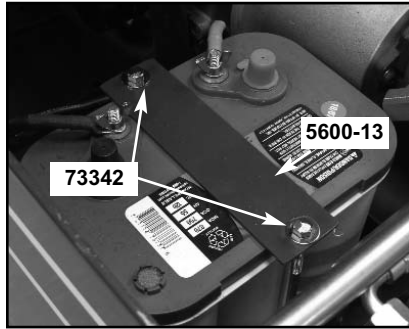

<u>PART #</u>	<u>DESCRIPTION</u>
5600-13	Battery Hold Down
5600-116	Battery (Blue Top)
73342	5/16-18 x 5 Hexhead Cap Screw (2)

WEIGHTS

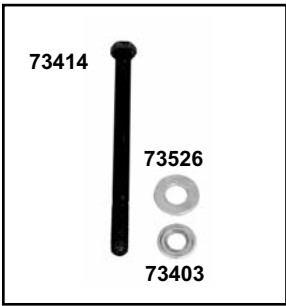

<u>PART#</u>	<u>DESCRIPTION</u>
5110-404	Rear Weight
5200-400-2	Front Weight Individually-36 lb. (12)
73403	1/2 Split Lock Washer
73406	1/2-13 x 1-1/4 Hexhead Cap Screw (Not Shown)
73414	1/2-13 x 7 Hexhead Bolt
73526	SAE 5/8 Flat Washer

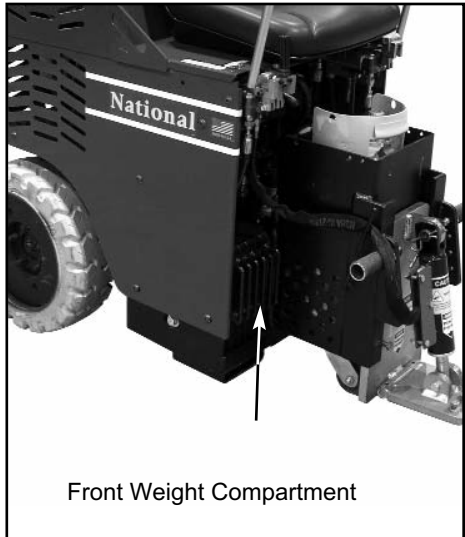

LABELS

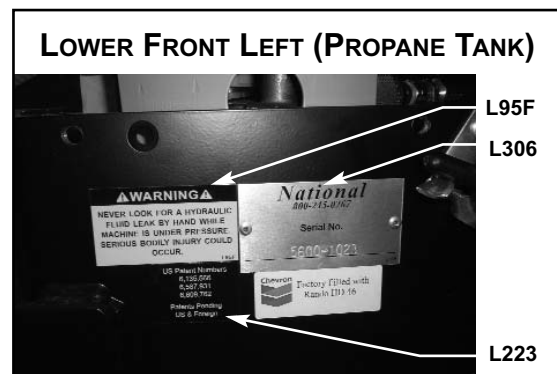
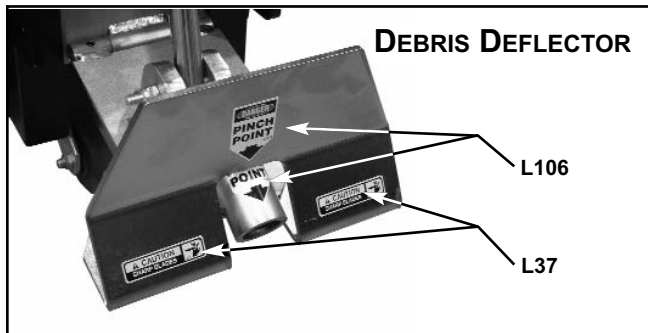
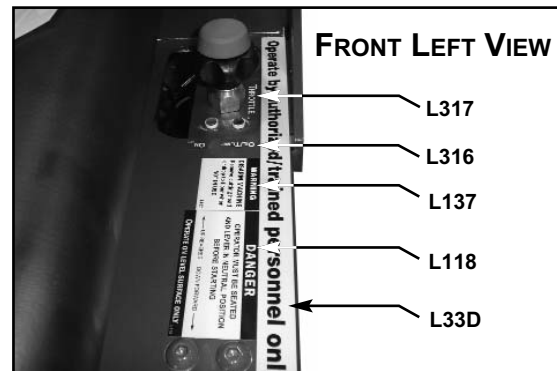
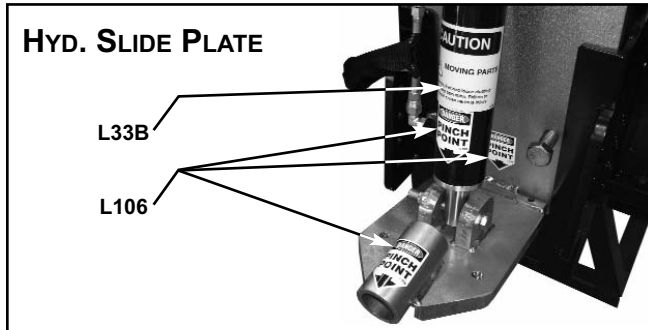
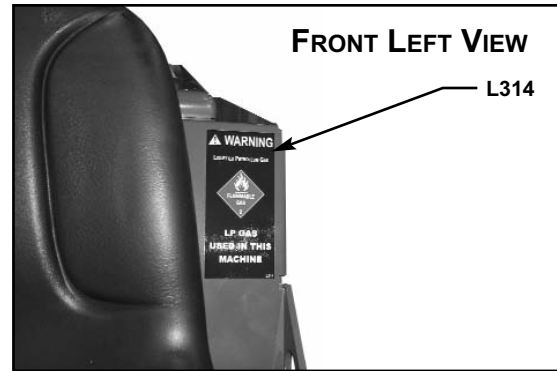
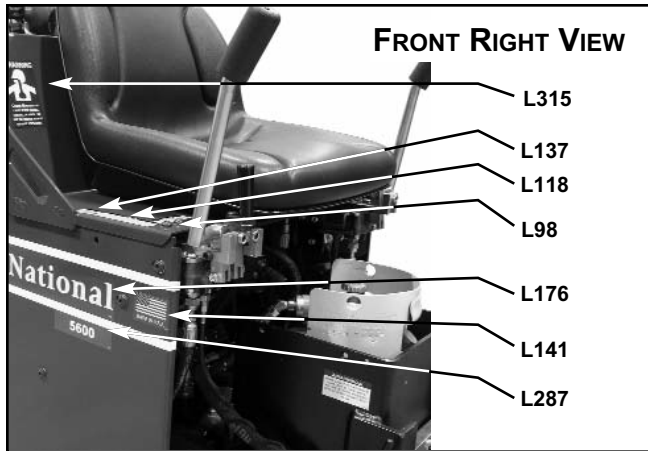

PART #	DESCRIPTION
L33B	Caution Moving Parts Label
L33D	Authorized Personnel Only Label
L37	Caution Sharp Blades Label (2)
L95F	Fluid Leak Label (2)
L98	Blade Lift Label
L106	Pinch Point Label (3)
L118	Operator Must be Seated Label (2)
L137	Disarm Machine Label (2)
L141	Flag/Made in USA Label (2) (one on each side)

PART #	DESCRIPTION
L176	National Label, Large (2) (one on each side)
L223	Patent Number Label
L287	5600 Stock Number Label (2) (one on each side)
L306	Serial Number Plate
L314	LP Gas Label
L315	Carbon Monoxide Label
L316	Oil/Temp On Label
L317	Throttle Label

LABELS

BACK VIEW

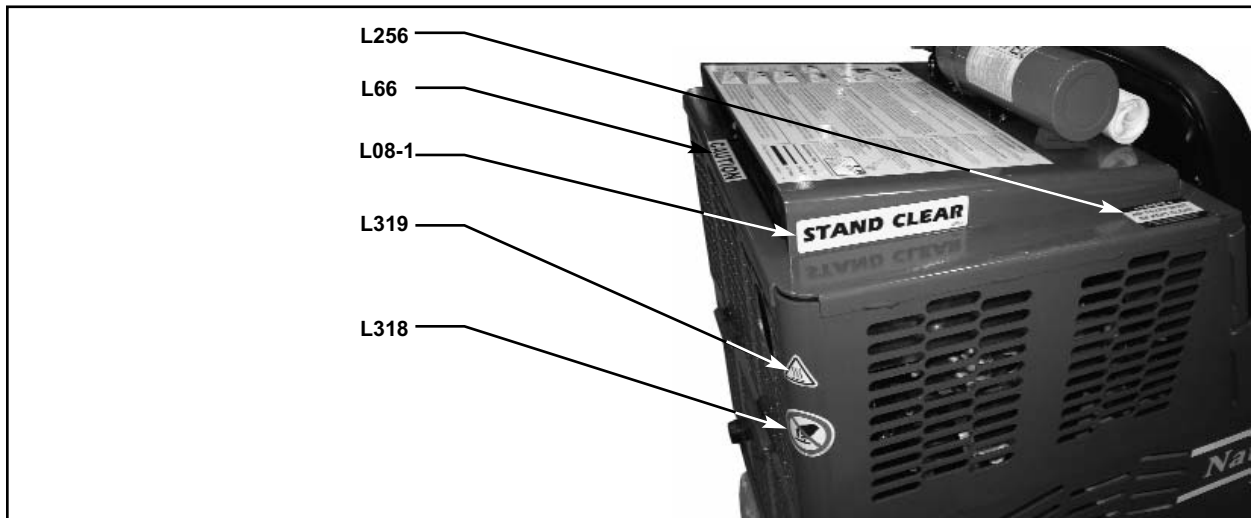
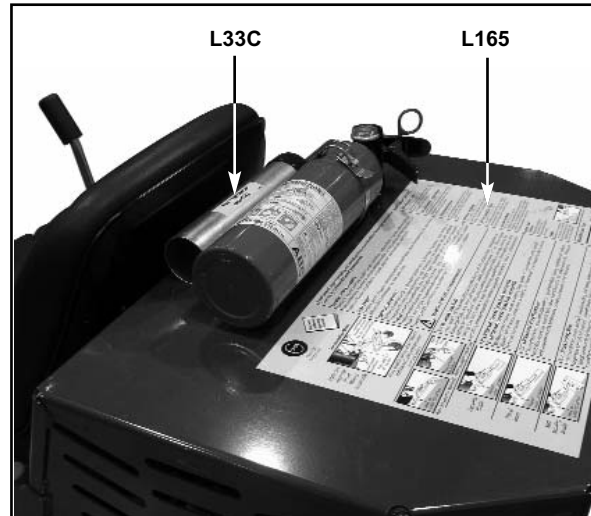
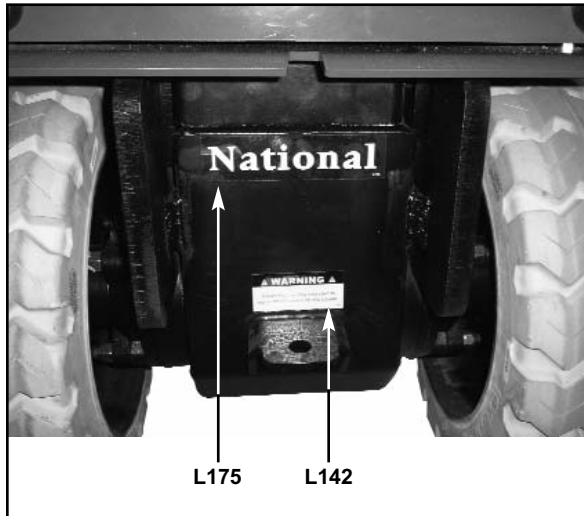

PART #	DESCRIPTION	PART #	DESCRIPTION
L08-1	Stand Clear Label (2)	L175	National Label, Small
L33C	Instruction Manual Label	L256	Air Filter Label (2)
L66	Caution Label	L318	Do Not Touch Label
L142	Trailer Hitch Label	L319	Burn Hazard Label
L165	Large Ride-On Label w/Blade Info		

ACCESSORIES

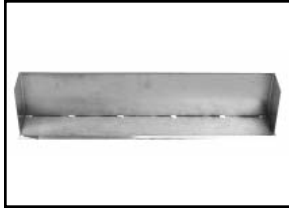

7074 TILE BOX

The Tile Box works for wind rowing and assists for a fast clean-up and collection of tile debris for quick removal. High abrasion alloy for a long lasting edge. Resharpens just like a blade. 5" x 27" x 6" box. Attaches to the #7050-27 Cutting Head (required).

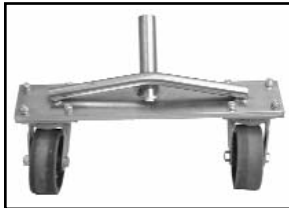

5110-100 FRONT WHEEL ASSEMBLY

Allows stability and safe transportation over any surface. Easy and quick to attach.

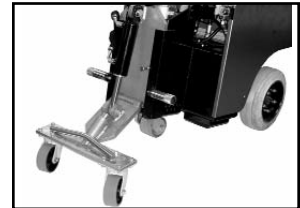

5110-100W Replacement Wheel Only

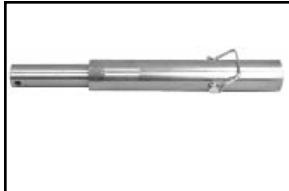

7050-15 CUTTING HEAD EXTENSION

Extension for cutting heads to reach under tight areas.



5110-111-3 OPTIONAL ARM RESTS/ SET

Optional Arm Rests for added comfort. Set includes left and right arm rest and mounting hardware.



7050-P PROPANE TANK

Vapor tank can hold approximately 14.25 pounds of propane • includes gauge and fill valve • Designed to withstand high impact



75007 LAPET CARBON MONOXIDE MONITOR

75008 LAPEL CARBON MONOXIDE CLIP

Carbon Monoxide detector badge, convenient to have on the jobsite when CO gas could be present • Can detect as little as 100ppm CO gas at approx. relative humidity range of 33 to 55% • If humidity is very high, it can detect concentrations as low as 20ppm • Presence of CO will change sensor from red to gray/black as concentration levels increase • Once exposed to fresh air, it will return back to red • After opened, lasts approximately 90 days.



5700-88 HOUR METER

Monitors the hours of usage

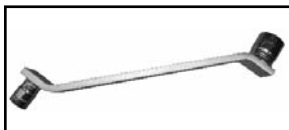

70549 Wrench

5600-VI Instruction Video (Not Shown)

BLADES & CUTTING HEADS

CUTTING HEADS

Swivel heads rotate to use the second sharp edge of the blade without having to remove the blade. Swivel head allows blade to stay in contact with the floor.

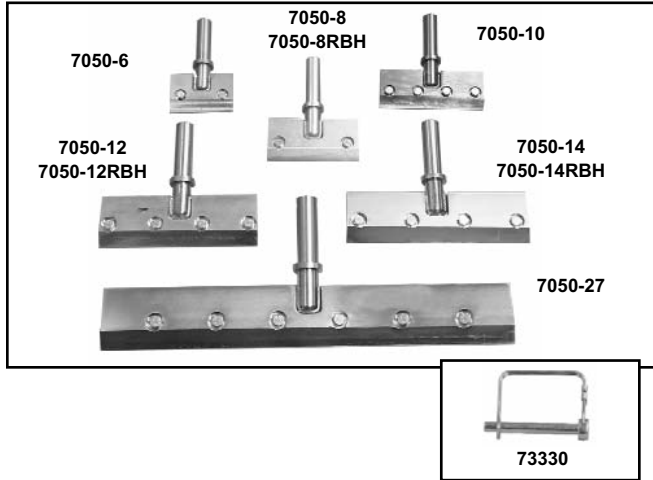

7050-6	6" CUTTING HEAD
7050-8	8" CUTTING HEAD
7050-10	10" CUTTING HEAD
7050-12	12" CUTTING HEAD
7050-14	14" CUTTING HEAD
7050-27	27" CUTTING HEAD
7050-8RBH	8" RAZOR BLADE HEAD
7050-12RBH	12" RAZOR BLADE HEAD
7050-14RBH	14" RAZOR BLADE HEAD
73330	5/16 X 2 PIN Secures cutting head assemblies

TAPERED CUTTING HEAD SHANK BLADES

Designed for removing wood and the toughest removals. Blades are mounted at an angle to achieve the optimum shear point for the best performance.

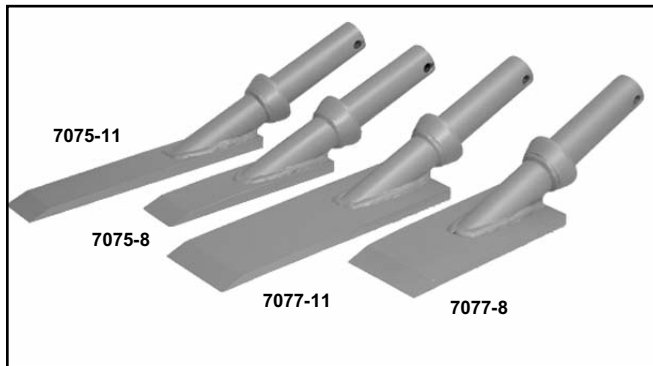

7075-8	2" X 8" TAPERED CUTTING HEAD SHANK
7075-11	2" X 11" TAPERED CUTTING HEAD SHANK
7077-8	3.5" X 8" TAPERED CUTTING HEAD SHANK
7077-11	3.5" X 11" TAPERED CUTTING HEAD SHANK

TAPERED CUTTING HEAD SHANKS WITH CARBIDE TIPS

Works on wood and ceramic. Blades are mounted at an angle to achieve the optimum shear point for the best performance. Nothing else performs like carbide when no other blade will work.

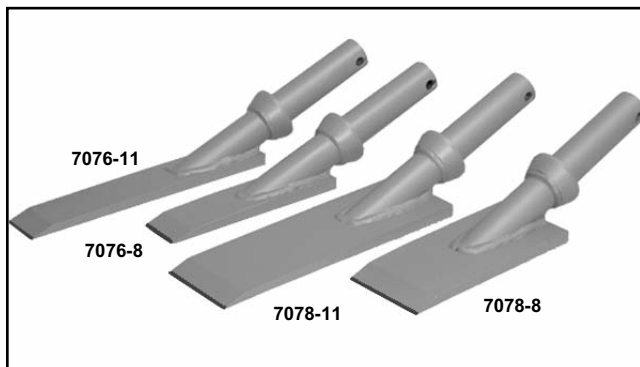

7076-8	2" X 8" TAPERED CUTTING HEAD SHANK W/ CARBIDE TIP
7076-11	2" X 11" TAPERED CUTTING HEAD SHANK W/ CARBIDE TIP
7078-8	3.5" X 8" TAPERED CUTTING HEAD W/ CARBIDE TIP
7078-11	3.5" X 11" TAPERED CUTTING HEAD SHANK W/ CARBIDE TIP

BLADES & CUTTING HEADS

STRAIGHT SHANK BLADES

The ultimate for tough removals. Works well for ceramic, wood and thick epoxy.



7070-2	2" STRAIGHT SHANK BLADE
7070-3	3" STRAIGHT SHANK BLADE
7070-4	4" STRAIGHT SHANK BLADE
7070-6	6" STRAIGHT SHANK BLADE

ANGLE SHANK/SHOE BLADES

The same application as the #7070 blades, but is mounted at an angle to achieve the optimum shear point for optimum performance. Works well for ceramic and thick epoxy.



7071-2	2" ANGLE SHANK/SHOE BLADE
7071-3	3" ANGLE SHANK/SHOE BLADE
7071-4	4" ANGLE SHANK/SHOE BLADE
7071-6	6" ANGLE SHANK/SHOE BLADE

STRAIGHT SHANKS WITH CARBIDE TIP

The same application as the #7070 blades, but are carbide tipped for holding a sharp edge for long periods. Works well for ceramic and thick epoxy.



7072-2	2" STRAIGHT SHANK W/ CARBIDE TIP
7072-3	3" STRAIGHT SHANK W/ CARBIDE TIP
7072-4	4" STRAIGHT SHANK W/ CARBIDE TIP
7072-6	6" STRAIGHT SHANK W/ CARBIDE TIP

EXTRA HEAVY DUTY CERAMIC EPOXY SHANKS WITH CARBIDE TIP

Designed for ceramic removal and thin-set rescraping. 1/2" of carbide which is twice the carbide of the #7072 & #7073 series blades. The extra carbide allows for maximum resharping. Strong enough to work on machines up to 3500 lbs.



7079-2	2" EXTRA HD CERAMIC EPOXY SHANK W/ CARBIDE TIP
7079-4	4" EXTRA HD CERAMIC EPOXY SHANK W/ CARBIDE TIP
7079-6	6" EXTRA HD CERAMIC EPOXY SHANK W/ CARBIDE TIP

5600 MACHINE WIRING

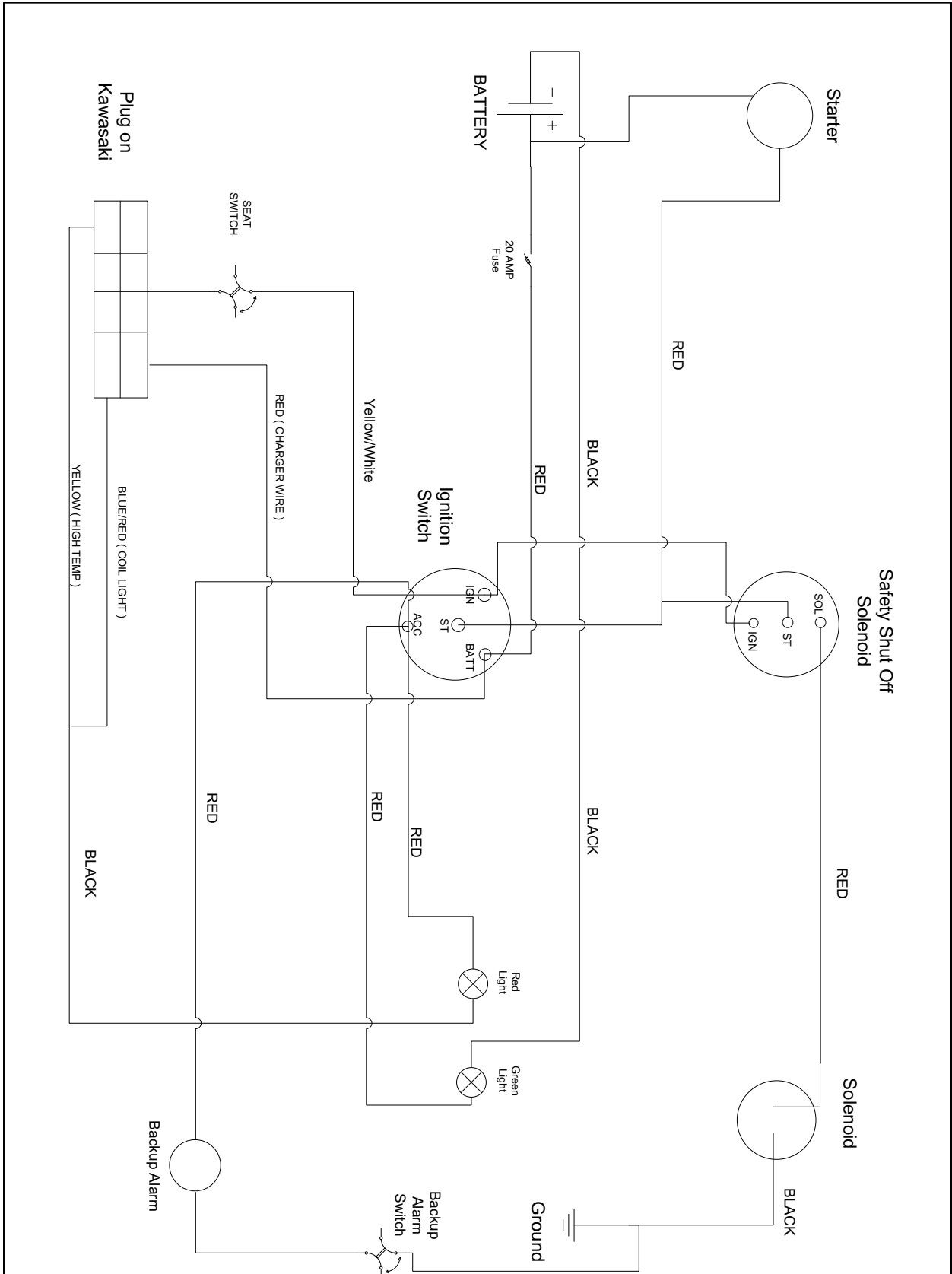

MATERIAL SAFETY DATA

Material Safety Data Sheet

SECTION 1 PRODUCT AND COMPANY IDENTIFICATION

Texaco Rando® HD 22 - 68

Product Number(s): CPS221655, CPS221657, CPS221658, CPS221659

Synonyms: Texaco Rando® HD 22, Texaco Rando® HD 32, Texaco Rando® HD 46, Texaco Rando® HD 68

Company Identification

Chevron Products Company
a division of Chevron U.S.A. Inc.
6001 Bollinger Canyon Road
San Ramon, CA 94583
United States of America
www.chevronlubricants.com

Transportation Emergency Response

CHEMTREC: (800) 424-9300 or (703) 527-3887

Health Emergency

Chevron Emergency Information Center: Located in the USA. International collect calls accepted. (800) 231-0623 or (510) 231-0623

Product Information

email : lubemsds@chevron.com
Product Information: 800-LUBE-TEK
MSDS Requests: 800-414-6737

SECTION 2 COMPOSITION/ INFORMATION ON INGREDIENTS

COMPONENTS	CAS NUMBER	AMOUNT
Highly refined mineral oil (C15 - C50)	Mixture	90 - 100 %weight

SECTION 3 HAZARDS IDENTIFICATION

IMMEDIATE HEALTH EFFECTS

Eye: Not expected to cause prolonged or significant eye irritation.

Skin: Contact with the skin is not expected to cause prolonged or significant irritation. Not expected to be harmful to internal organs if absorbed through the skin. High-Pressure Equipment Information: Accidental high-velocity injection under the skin of materials of this type may result in serious injury. Seek medical attention at once should an accident like this occur. The initial wound at the injection site may not appear to be serious at first; but, if left untreated, could result in disfigurement or amputation of the affected part.

Ingestion: Not expected to be harmful if swallowed.

Inhalation: Not expected to be harmful if inhaled. Contains a petroleum-based mineral oil. May cause respiratory irritation or other pulmonary effects following prolonged or repeated inhalation of oil mist at airborne levels above the recommended mineral oil mist exposure limit. Symptoms of respiratory irritation may include coughing and difficulty breathing.

SECTION 4 FIRST AID MEASURES

Eye: No specific first aid measures are required. As a precaution, remove contact lenses, if worn, and flush eyes with water.

MATERIAL SAFETY DATA

Skin: No specific first aid measures are required. As a precaution, remove clothing and shoes if contaminated. To remove the material from skin, use soap and water. Discard contaminated clothing and shoes or thoroughly clean before reuse.

Ingestion: No specific first aid measures are required. Do not induce vomiting. As a precaution, get medical advice.

Inhalation: No specific first aid measures are required. If exposed to excessive levels of material in the air, move the exposed person to fresh air. Get medical attention if coughing or respiratory discomfort occurs.

Note to Physicians: In an accident involving high-pressure equipment, this product may be injected under the skin. Such an accident may result in a small, sometimes bloodless, puncture wound. However, because of its driving force, material injected into a fingertip can be deposited into the palm of the hand. Within 24 hours, there is usually a great deal of swelling, discoloration, and intense throbbing pain. Immediate treatment at a surgical emergency center is recommended.

SECTION 5 FIRE FIGHTING MEASURES

Leaks/ruptures in high pressure system using materials of this type can create a fire hazard when in the vicinity of ignition sources (eg. open flame, pilot lights, sparks, or electric arcs).

FIRE CLASSIFICATION:

OSHA Classification (29 CFR 1910.1200): Not classified by OSHA as flammable or combustible.

NFPA RATINGS: Health: 0 Flammability: 1 Reactivity: 0

FLAMMABLE PROPERTIES:

Flashpoint: (Cleveland Open Cup) 150 °C (302 °F) (Min)

Autoignition: No Data Available

Flammability (Explosive) Limits (% by volume in air): Lower: Not Applicable Upper: Not Applicable

EXTINGUISHING MEDIA: Use water fog, foam, dry chemical or carbon dioxide (CO₂) to extinguish flames.

PROTECTION OF FIRE FIGHTERS:

Fire Fighting Instructions: This material will burn although it is not easily ignited. For fires involving this material, do not enter any enclosed or confined fire space without proper protective equipment, including self-contained breathing apparatus.

Combustion Products: Highly dependent on combustion conditions. A complex mixture of airborne solids, liquids, and gases including carbon monoxide, carbon dioxide, and unidentified organic compounds will be evolved when this material undergoes combustion.

SECTION 6 ACCIDENTAL RELEASE MEASURES

Protective Measures: Eliminate all sources of ignition in vicinity of spilled material.

Spill Management: Stop the source of the release if you can do it without risk. Contain release to prevent further contamination of soil, surface water or groundwater. Clean up spill as soon as possible, observing precautions in Exposure Controls/Personal Protection. Use appropriate techniques such as applying non-combustible absorbent materials or pumping. Where feasible and appropriate, remove contaminated soil. Place contaminated materials in disposable containers and dispose of in a manner consistent with applicable regulations.

Reporting: Report spills to local authorities and/or the U.S. Coast Guard's National Response Center at (800) 424-8802 as appropriate or required.

SECTION 7 HANDLING AND STORAGE

Precautionary Measures: DO NOT USE IN HIGH PRESSURE SYSTEMS in the vicinity of flames, sparks and hot surfaces. Use only in well ventilated areas. Keep container closed.

General Handling Information: Avoid contaminating soil or releasing this material into sewage and drainage systems and bodies of water.

Static Hazard: Electrostatic charge may accumulate and create a hazardous condition when handling this material. To minimize this hazard, bonding and grounding may be necessary but may not, by themselves, be sufficient. Review all operations which have the potential of generating and accumulating an electrostatic charge and/or a flammable atmosphere (including tank and container filling, splash filling, tank cleaning, sampling, gauging, switch loading, filtering, mixing, agitation, and vacuum truck operations) and use appropriate mitigating procedures. For more information, refer to OSHA Standard 29 CFR 1910.106, 'Flammable and Combustible

MATERIAL SAFETY DATA

Liquids', National Fire Protection Association (NFPA 77, 'Recommended Practice on Static Electricity', and/or the American Petroleum Institute (API) Recommended Practice 2003, 'Protection Against Ignitions Arising Out of Static, Lightning, and Stray Currents'.

Container Warnings: Container is not designed to contain pressure. Do not use pressure to empty container or it may rupture with explosive force. Empty containers retain product residue (solid, liquid, and/or vapor) and can be dangerous. Do not pressurize, cut, weld, braze, solder, drill, grind, or expose such containers to heat, flame, sparks, static electricity, or other sources of ignition. They may explode and cause injury or death. Empty containers should be completely drained, properly closed, and promptly returned to a drum reconditioner or disposed of properly.

SECTION 8 EXPOSURE CONTROLS/PERSONAL PROTECTION

GENERAL CONSIDERATIONS:

Consider the potential hazards of this material (see Section 3), applicable exposure limits, job activities, and other substances in the work place when designing engineering controls and selecting personal protective equipment. If engineering controls or work practices are not adequate to prevent exposure to harmful levels of this material, the personal protective equipment listed below is recommended. The user should read and understand all instructions and limitations supplied with the equipment since protection is usually provided for a limited time or under certain circumstances.

ENGINEERING CONTROLS:

Use in a well-ventilated area.

PERSONAL PROTECTIVE EQUIPMENT

Eye/Face Protection: No special eye protection is normally required. Where splashing is possible, wear safety glasses with side shields as a good safety practice.

Skin Protection: No special protective clothing is normally required. Where splashing is possible, select protective clothing depending on operations conducted, physical requirements and other substances in the workplace. Suggested materials for protective gloves include: 4H (PE/EVAL), Nitrile Rubber, Silver Shield, Viton.

Respiratory Protection: No respiratory protection is normally required.

If user operations generate an oil mist, determine if airborne concentrations are below the occupational exposure limit for mineral oil mist. If not, wear an approved respirator that provides adequate protection from the measured concentrations of this material. For air-purifying respirators use a particulate cartridge.

Use a positive pressure air-supplying respirator in circumstances where air-purifying respirators may not provide adequate protection.

SECTION 9 PHYSICAL AND CHEMICAL PROPERTIES

Attention: the data below are typical values and do not constitute a specification.

Color: Yellow

Physical State: Liquid

Odor: Petroleum odor

pH: Not Applicable

Vapor Pressure: <0.01 mmHg @ 37.8 °C (100 °F)

Vapor Density (Air = 1): >1

Boiling Point: >315.6°C (600°F)

Solubility: Soluble in hydrocarbons; insoluble in water

Freezing Point: Not Applicable

Melting Point: Not Applicable

Specific Gravity: 0.86 - 0.87 @ 15.6°C (60.1°F) / 15.6°C (60.1°F)

Density: 0.86 kg/l - 0.9 kg/l @ 15°C (59°F)

Viscosity: 22 cSt - 61.2 cSt @ 40°C (104°F) (Min)

SECTION 10 STABILITY AND REACTIVITY

Chemical Stability: This material is considered stable under normal ambient and anticipated storage and handling conditions of temperature and pressure.

Incompatibility With Other Materials: May react with strong acids or strong oxidizing agents, such as chlorates, nitrates, peroxides, etc.

Hazardous Decomposition Products: None known (None expected)

MATERIAL SAFETY DATA

Hazardous Polymerization: Hazardous polymerization will not occur.

SECTION 11 TOXICOLOGICAL INFORMATION

IMMEDIATE HEALTH EFFECTS

Eye Irritation: The eye irritation hazard is based on evaluation of data for similar materials or product components.

Skin Irritation: The skin irritation hazard is based on evaluation of data for similar materials or product components.

Skin Sensitization: No product toxicology data available.

Acute Dermal Toxicity: The acute dermal toxicity hazard is based on evaluation of data for similar materials or product components.

Acute Oral Toxicity: The acute oral toxicity hazard is based on evaluation of data for similar materials or product components.

Acute Inhalation Toxicity: The acute inhalation toxicity hazard is based on evaluation of data for similar materials or product components.

ADDITIONAL TOXICOLOGY INFORMATION:

This product contains petroleum base oils which may be refined by various processes including severe solvent extraction, severe hydrocracking, or severe hydrotreating. None of the oils requires a cancer warning under the OSHA Hazard Communication Standard (29 CFR 1910.1200). These oils have not been listed in the National Toxicology Program (NTP) Annual Report nor have they been classified by the International Agency for Research on Cancer (IARC) as; carcinogenic to humans (Group 1), probably carcinogenic to humans (Group 2A), or possibly carcinogenic to humans (Group 2B). These oils have not been classified by the American Conference of Governmental Industrial Hygienists (ACGIH) as: confirmed human carcinogen (A1), suspected human carcinogen (A2), or confirmed animal carcinogen with unknown relevance to humans (A3).

SECTION 12 ECOLOGICAL INFORMATION

ECOTOXICITY

This material is not expected to be harmful to aquatic organisms. The ecotoxicity hazard is based on an evaluation of data for the components or a similar material.

ENVIRONMENTAL FATE

This material is not expected to be readily biodegradable.

SECTION 13 DISPOSAL CONSIDERATIONS

Use material for its intended purpose or recycle if possible. Oil collection services are available for used oil recycling or disposal. Place contaminated materials in containers and dispose of in a manner consistent with applicable regulations. Contact your sales representative or local environmental or health authorities for approved disposal or recycling methods.

SECTION 14 TRANSPORT INFORMATION

The description shown may not apply to all shipping situations. Consult 49CFR, or appropriate Dangerous Goods Regulations, for additional description requirements (e.g., technical name) and mode-specific or quantity-specific shipping requirements.

DOT Shipping Description: PETROLEUM LUBRICATING OIL, NOT REGULATED AS A HAZARDOUS MATERIAL FOR TRANSPORTATION UNDER 49 CFR

Additional Information: NOT HAZARDOUS BY U.S. DOT. ADR/RID HAZARD CLASS NOT APPLICABLE.

IMO/IMDG Shipping Description: PETROLEUM LUBRICATING OIL; NOT REGULATED AS DANGEROUS GOODS FOR TRANSPORT UNDER THE IMDG CODE

ICAO/IATA Shipping Description: PETROLEUM LUBRICATING OIL; NOT REGULATED AS DANGEROUS GOODS FOR TRANSPORT UNDER ICAO

MATERIAL SAFETY DATA

SECTION 15 REGULATORY INFORMATION

- EPCRA 311/312 CATEGORIES:** 1. Immediate (Acute) Health Effects: NO
2. Delayed (Chronic) Health Effects: NO
3. Fire Hazard: NO
4. Sudden Release of Pressure Hazard: NO
5. Reactivity Hazard: NO

REGULATORY LISTS SEARCHED:

01-1=IARC Group 1	03=EPCRA 313
01-2A=IARC Group 2A	04=CA Proposition 65
01-2B=IARC Group 2B	05=MA RTK
02=NTP Carcinogen0	6=NJ RTK
	07=PA RTK

No components of this material were found on the regulatory lists above.

CHEMICAL INVENTORIES:

All components comply with the following chemical inventory requirements: AICS (Australia), DSL (Canada), ENCS (Japan), IECSC (China), KECI (Korea), PICCS (Philippines), TSCA (United States).

One or more components is listed on ELINCS (European Union). Secondary notification by the importer may be required.

NEW JERSEY RTK CLASSIFICATION:

Under the New Jersey Right-to-Know Act L. 1983 Chapter 315 N.J.S.A. 34:5A-1 et. seq., the product is to be identified as follows: PETROLEUM OIL (Hydraulic oil)

WHMIS CLASSIFICATION:

This product is not considered a controlled product according to the criteria of the Canadian Controlled Products Regulations.

SECTION 16 OTHER INFORMATION

NFPA RATINGS: Health: 0 Flammability: 1 Reactivity: 0

HMIS RATINGS: Health: 1 Flammability: 1 Reactivity: 0
(0-Least, 1-Slight, 2-Moderate, 3-High, 4-Extreme, PPE:- Personal Protection Equipment Index recommendation, *- Chronic Effect Indicator). These values are obtained using the guidelines or published evaluations prepared by the National Fire Protection Association (NFPA) or the National Paint and Coating Association (for HMIS ratings).

LABEL RECOMMENDATION:

Label Category : INDUSTRIAL OIL 1 - IND1

REVISION STATEMENT: This revision updates the following sections of this Material Safety Data Sheet: 2.
Revision Date: January 15, 2007

ABBREVIATIONS THAT MAY HAVE BEEN USED IN THIS DOCUMENT:

TLV - Threshold Limit Value	TWA - Time Weighted Average
STEL - Short-term Exposure Limit	PEL - Permissible Exposure Limit
	CAS - Chemical Abstract Service Number
ACGIH - American Conference of Government Industrial Hygienists	IMO/IMDG - International Maritime Dangerous Goods Code
API - American Petroleum Institute	MSDS - Material Safety Data Sheet

MATERIAL SAFETY DATA

CVX - Chevron	NFPA - National Fire Protection Association (USA)
DOT - Department of Transportation (USA)	NTP - National Toxicology Program (USA)
IARC - International Agency for Research on Cancer	OSHA - Occupational Safety and Health Administration

Prepared according to the OSHA Hazard Communication Standard (29 CFR 1910.1200) and the ANSI MSDS Standard (Z400.1) by the Chevron Energy Technology Company, 100 Chevron Way, Richmond, California 94802.

The above information is based on the data of which we are aware and is believed to be correct as of the date hereof. Since this information may be applied under conditions beyond our control and with which we may be unfamiliar and since data made available subsequent to the date hereof may suggest modifications of the information, we do not assume any responsibility for the results of its use. This information is furnished upon condition that the person receiving it shall make his own determination of the suitability of the material for his particular purpose.

FIRE EXTINGUISHER MATERIAL SAFETY DATA

- [1. PRODUCT AND COMPANY IDENTIFICATION](#)
- [2. COMPOSITION/INFORMATION ON THE COMPONENTS](#)
- [3. HAZARD IDENTIFICATION](#)
- [4. FIRST AID MEASURES](#)
- [5. FIRE FIGHTING MEASURES](#)
- [6. ACCIDENTAL RELEASE MEASURES](#)
- [7. HANDLING AND STORAGE](#)
- [8. EXPOSURE CONTROLS/PERSONAL PROTECTION](#)
- [9. PHYSICAL AND CHEMICAL PROPERTIES](#)
- [10. STABILITY AND REACTIVITY](#)
- [11. TOXICOLOGICAL INFORMATION](#)
- [12. ECOLOGICAL INFORMATION](#)
- [13. DISPOSAL](#)
- [14. TRANSPORT INFORMATION](#)
- [15. REGULATORY INFORMATION](#)
- [16. OTHER INFORMATION](#)

KIDDE
A UTC FIRE & SECURITY COMPANY

MATERIAL SAFETY DATA SHEET

KIDDE 55 MULTI-PURPOSE DRY CHEMICAL (FIRE EXTINGUISHING AGENT)

1. PRODUCT AND COMPANY IDENTIFICATION

PRODUCT NAME:
KIDDE 55 MULTI - PURPOSE DRY CHEMICAL (FIRE EXTINGUISHING AGENT)

OTHER TRADE NAMES: ABC, AMMONIUM PHOSPHATE, MONOAMMONIUM PHOSPHATE

MANUFACTURER/SUPPLIER:
KIDDE - RESIDENTIAL AND COMMERCIAL
A UNITED TECHNOLOGIES COMPANY

ADDRESS:
1016 CORPORATE PARK DRIVE
MEBANE, NC 27302
USA

PHONE NUMBER:
(919) 304-8200
(919) 563-5911

CHEMTREC NUMBER (FOR EMERGENCIES ONLY):
(800) 424-9300
(703) 527-3887 (INTERNATIONAL)

REVISION DATE: AUGUST 7, 2007

MSDS DATE: JANUARY 15, 2007

THIS MSDS HAS BEEN COMPILED IN ACCORDANCE WITH - EC DIRECTIVE
91/155/EC - OSHA'S HAZCOM STANDARD (29 CFR 1910.1200)

FIRE EXTINGUISHER MATERIAL SAFETY DATA

2. COMPOSITION/INFORMATION ON THE COMPONENTS

COMPONENT NAME	CAS#/CODES	CONCENTRATION	R PHRASES	EU CLASSIFICATION
MONOAMMONIUM PHOSPHATE	7722-76-1 EC#2317645	55 - 65%	NONE	NONE
AMMONIUM SULFATE	7783-20-2 EC#2319841	30 - 40%	NONE	NONE
MICA	12001-26-2	1 - 4%	NONE	NONE
CLAY	8031-18-3	<2%	NONE	NONE
AMORPHOUS SILICA	7631-86-9 EC#2315454	<2%	NONE	NONE
DYE	NA	<0.1%	NONE	NONE

3. HAZARD IDENTIFICATION

EU MAIN HAZARDS: NON HAZARDOUS POWDER

ROUTES OF ENTRY:

EYE CONTACT
INHALATION
SKIN CONTACT

CARCINOGENIC STATUS: SEE SECTION 11 - TOXICITY

TARGET ORGANS:

RESPIRATORY SYSTEM
SKIN
EYE

HEALTH EFFECTS - EYES:

CONTACT FOR SHORT PERIODS OF TIME MAY CAUSE IRRITATION.

HEALTH EFFECTS - SKIN: CONTACT MAY CAUSE MILD IRRITATION.

HEALTH EFFECTS - INGESTION: INGESTION IS NOT AN EXPECTED ROUTE OF EXPOSURE.

HEALTH EFFECTS - INHALATION:

MAY IRRITATE THE RESPIRATORY TRACT. MAY CAUSE TRANSIENT COUGH AND SHORTNESS OF BREATH.

4. FIRST AID MEASURES

EYES:

IMMEDIATELY FLOOD THE EYE WITH PLENTY OF WATER OR WARM WATER FOR AT LEAST 15 MINUTES, HOLDING THE EYE OPEN. OBTAIN MEDICAL ATTENTION IF SORENESS OR REDNESS PERSISTS.

SKIN:

WASH AFFECTED AREA WITH SOAP AND WATER. OBTAIN MEDICAL ATTENTION IF IRRITATION PERSISTS.

INGESTION:

DILUTE BY DRINKING LARGE QUANTITIES OF WATER AND OBTAIN MEDICAL ATTENTION.

INHALATION:

MOVE VICTIM TO FRESH AIR. OBTAIN MEDICAL ATTENTION IMMEDIATELY FOR ANY BREATHING DIFFICULTY.

ADVICE TO PHYSICIANS: TREAT SYMPTOMATICALLY.

FIRE EXTINGUISHER MATERIAL SAFETY DATA

5. FIRE FIGHTING MEASURES

EXTINGUISHING MEDIA:

THIS PREPARATION IS USED AS AN EXTINGUISHING AGENT AND THEREFORE IS NOT A PROBLEM WHEN TRYING TO CONTROL A BLAZE. USE EXTINGUISHING AGENT APPROPRIATE TO OTHER MATERIALS INVOLVED. KEEP PRESSURIZED EXTINGUISHERS AND SURROUNDINGS COOL WITH WATER SPRAY AS THEY MAY RUPTURE OR BURST IN THE HEAT OF A FIRE.

UNUSUAL FIRE AND EXPLOSION HAZARDS:

PRESSURIZED CONTAINERS MAY EXPLODE IN HEAT OF FIRE.

PROTECTIVE EQUIPMENT FOR FIRE-FIGHTING:

WEAR FULL PROTECTIVE CLOTHING AND SELF-CONTAINED BREATHING APPARATUS AS APPROPRIATE FOR SPECIFIC FIRE CONDITIONS.

6. ACCIDENTAL RELEASE MEASURES

SWEEP UP OR VACUUM. PREVENT SKIN AND EYE CONTACT. WEAR APPROPRIATE PROTECTIVE EQUIPMENT.

7. HANDLING AND STORAGE

PRESSURIZED EXTINGUISHERS SHOULD BE PROPERLY STORED AND SECURED TO PREVENT FALLING OR BEING KNOCKED OVER. DO NOT DRAG, SLIDE OR ROLL EXTINGUISHERS. DO NOT DROP EXTINGUISHERS OR PERMIT THEM TO STRIKE AGAINST EACH OTHER. NEVER APPLY FLAME OR LOCALIZED HEAT DIRECTLY TO ANY PART OF THE EXTINGUISHER OR PLASTIC CONTAINER. STORE PRESSURIZED EXTINGUISHERS AND PLASTIC CONTAINERS AWAY FROM HIGH HEAT SOURCES.

STORAGE AREA SHOULD BE:

COOL
DRY
WELL VENTILATED
UNDER COVER
OUT OF DIRECT SUNLIGHT

8. EXPOSURE CONTROLS/PERSONAL PROTECTION

OCCUPATIONAL EXPOSURE STANDARDS:

OCCUPATIONAL EXPOSURE LIMITS ARE LISTED BELOW, IF THEY EXIST.

MICA:

ACGIH TLV: 3 MG/M3 TWA, MEASURED AS RESPIRABLE FRACTION OF THE AEROSOL.
OSHA PEL: 20 MPPCF, <1% CRYSTALLINE SILICA

NUISANCE DUST LIMIT:

OSHA PEL:
50 MPPCF OR 15 MG/M3 TWA, TOTAL DUST
15 MPPCF OR 5 MG/M3 TWA, RESPIRABLE FRACTION

ENGINEERING CONTROL MEASURES:

USE WITH ADEQUATE VENTILATION. THERE SHOULD BE LOCAL PROCEDURES FOR THE SELECTION, TRAINING, INSPECTION AND MAINTENANCE OF THIS EQUIPMENT. WHEN USED IN LARGE VOLUMES, USE LOCAL EXHAUST VENTILATION.

FIRE EXTINGUISHER MATERIAL SAFETY DATA

8. EXPOSURE CONTROLS/PERSONAL PROTECTION

RESPIRATORY PROTECTION:

NOT NORMALLY REQUIRED. USE DUST MASK WHERE DUSTINESS IS PREVALENT, OR TLV IS EXCEEDED.

HAND PROTECTION:

NOT NORMALLY NEEDED WHEN USED AS A PORTABLE FIRE EXTINGUISHER. USE GLOVES IF IRRITATION OCCURS.

EYE PROTECTION: CHEMICAL GOGGLES OR SAFETY GLASSES WITH SIDE SHIELDS.

BODY PROTECTION: NORMAL WORK WEAR.

9. PHYSICAL AND CHEMICAL PROPERTIES

PHYSICAL STATE: POWDER

COLOR: PALE YELLOW

ODOR: ODORLESS

SPECIFIC GRAVITY: NOT AVAILABLE

BOILING RANGE/POINT (DEG. C/F): NOT APPLICABLE

FLASH POINT (PMCC) (DEG. C/F): NOT FLAMMABLE

SOLUBILITY IN WATER: NOT APPLICABLE

VAPOR DENSITY (AIR = 1): HEAVIER THAN AIR.

VAPOR PRESSURE: NOT APPLICABLE

EVAPORATION RATE: NOT APPLICABLE

10. STABILITY AND REACTIVITY

STABILITY: STABLE UNDER NORMAL CONDITIONS.

CONDITIONS TO AVOID:

HEAT

HIGH TEMPERATURES

EXPOSURE TO DIRECT SUNLIGHT

MATERIALS TO AVOID:

STRONG OXIDIZING AGENTS

STRONG ACIDS

SODIUM HYPOCHLORITE

HAZARDOUS POLYMERIZATION: WILL NOT OCCUR.

HAZARDOUS DECOMPOSITION PRODUCTS:

OXIDES OF CARBON

AMMONIA

OXIDES OF PHOSPHORUS

NITROGEN OXIDES

FIRE EXTINGUISHER MATERIAL SAFETY DATA

11. TOXICOLOGICAL INFORMATION

ACUTE TOXICITY: LOW ORDER OF ACUTE TOXICITY.

CHRONIC TOXICITY/CARCINOGENICITY:

THIS PRODUCT IS NOT EXPECTED TO CAUSE LONG TERM ADVERSE HEALTH EFFECTS.

MICA AND CLAY MAY CONTAIN SMALL QUANTITIES OF QUARTZ (CRYSTALLINE SILICA) AS AN IMPURITY. PROLONGED EXPOSURE TO RESPIRABLE CRYSTALLINE SILICA DUST AT CONCENTRATIONS EXCEEDING THE OCCUPATIONAL EXPOSURE LIMITS MAY INCREASE THE RISK OF DEVELOPING A DISABLING LUNG DISEASE KNOWN AS SILICOSIS. IARC FOUND LIMITED EVIDENCE FOR PULMONARY CARCINOGENICITY OF CRYSTALLINE SILICA IN HUMANS.

GENOTOXICITY: THIS PRODUCT IS NOT EXPECTED TO CAUSE ANY MUTAGENIC EFFECTS.

REPRODUCTIVE/DEVELOPMENTAL TOXICITY:

THIS PRODUCT IS NOT EXPECTED TO CAUSE ADVERSE REPRODUCTIVE EFFECTS.

12. ECOLOGICAL INFORMATION

MOBILITY: NO RELEVANT STUDIES IDENTIFIED.

PERSISTENCE/DEGRADABILITY: NO RELEVANT STUDIES IDENTIFIED.

BIO-ACCUMULATION: NO RELEVANT STUDIES IDENTIFIED.

ECOTOXICITY: NO RELEVANT STUDIES IDENTIFIED.

13. DISPOSAL

DISPOSE OF CONTAINER IN ACCORDANCE WITH ALL APPLICABLE LOCAL AND NATIONAL REGULATIONS. DO NOT CUT, PUNCTURE OR WELD ON OR NEAR TO THE CONTAINER. NO HARM TO THE ENVIRONMENT IS EXPECTED FROM THIS PREPARATION.

14. TRANSPORT INFORMATION

DOT CFR 172.101 DATA: NOT REGULATED

UN PROPER SHIPPING NAME: NOT REGULATED

UN CLASS: NONE

UN NUMBER: NONE

UN PACKAGING GROUP: NONE

15. REGULATORY INFORMATION

EU LABEL INFORMATION:

CLASSIFICATION AND LABELLING HAVE BEEN PERFORMED ACCORDING TO EU DIRECTIVES 67/548/EEC AND 99/45/EC INCLUDING AMENDMENTS.

EU HAZARD SYMBOL AND INDICATION OF DANGER.:

THIS PREPARATION IS NOT CLASSIFIED AS DANGEROUS.

R PHRASES: NONE

S PHRASES: NONE.

FIRE EXTINGUISHER MATERIAL SAFETY DATA

15. REGULATORY INFORMATION (Continued)

US REGULATIONS (FEDERAL, STATE) AND INTERNATIONAL CHEMICAL REGISTRATION LAWS:

TSCA LISTING:

THIS PRODUCT CONTAINS INGREDIENTS THAT ARE LISTED ON OR EXEMPT FROM LISTING ON THE EPA TOXIC SUBSTANCE CONTROL ACT CHEMICAL SUBSTANCE INVENTORY.

EINECS LISTING:

ALL INGREDIENTS IN THIS PRODUCT HAVE NOT BEEN VERIFIED FOR LISTING ON THE EUROPEAN INVENTORY OF EXISTING COMMERCIAL CHEMICAL SUBSTANCES (EINECS) OR THE EUROPEAN LIST OF NEW CHEMICAL SUBSTANCES (ELINCS).

DSL/NDL (CANADIAN) LISTING:

ALL INGREDIENTS IN THIS PRODUCT ARE LISTED ON THE DOMESTIC SUBSTANCE LIST (DSL) OR THE NON-DOMESTIC SUBSTANCE LIST (NDSL) OR ARE EXEMPT FROM LISTING.

WHMIS CLASSIFICATION:

D2B

THIS PRODUCT WAS CLASSIFIED IN ACCORDANCE WITH THE HAZARD CRITERIA OF THE CANADIAN CONTROLLED PRODUCTS REGULATIONS AND THE MSDS CONTAINS ALL THE INFORMATION REQUIRED BY THESE REGULATIONS.

MA RIGHT TO KNOW LAW:

ALL COMPONENTS HAVE BEEN CHECKED FOR INCLUSION ON THE MASSACHUSETTS SUBSTANCE LIST (MSL). THOSE COMPONENTS PRESENT AT OR ABOVE THE DE MINIMIS CONCENTRATION INCLUDE:

MICA	(12001-26-2)	1 - 4%
AMORPHOUS SILICA	(7631-86-9)	<2%
AMMONIUM SULFATE	(7783-20-2)	30 - 40%

PA RIGHT TO KNOW LAW:

THIS PRODUCT CONTAINS THE FOLLOWING CHEMICALS FOUND ON THE PENNSYLVANIA HAZARDOUS SUBSTANCE LIST:

MICA	(12001-26-2)	1 - 4%
AMORPHOUS SILICA	(7631-86-9)	<2%
AMMONIUM SULFATE	(7783-20-2)	30 - 40%

NJ RIGHT TO KNOW LAW:

THIS PRODUCT CONTAINS THE FOLLOWING CHEMICALS FOUND ON THE NJ RIGHT TO KNOW HAZARDOUS SUBSTANCE LIST:

MICA	(12001-26-2)	1 - 4%
AMORPHOUS SILICA	(7631-86-9)	<2%

CALIFORNIA PROPOSITION 65:

THIS PRODUCT DOES NOT CONTAIN MATERIALS WHICH THE STATE OF CALIFORNIA HAS FOUND TO CAUSE CANCER, BIRTH DEFECTS OR OTHER REPRODUCTIVE HARM.

SARA TITLE III SECT. 302 (EHS):

THIS PRODUCT DOES NOT CONTAIN ANY CHEMICALS SUBJECT TO SARA TITLE III SECTION 302.

SARA TITLE III SECT. 304:

THIS PRODUCT DOES NOT CONTAIN ANY CHEMICALS SUBJECT TO SARA TITLE III SECTION 304.

SARA TITLE III SECT. 311/312 CATEGORIZATION:

IMMEDIATE (ACUTE) HEALTH HAZARD

SARA TITLE III SECT. 313:

THIS PRODUCT DOES NOT CONTAIN ANY CHEMICALS THAT ARE LISTED IN SECTION 313 AT OR ABOVE DE MINIMIS CONCENTRATIONS.

FIRE EXTINGUISHER MATERIAL SAFETY DATA

16. OTHER INFORMATION

NFPA RATINGS:

NFPA CODE FOR HEALTH 1
NFPA CODE FOR FLAMMABILITY 0
NFPA CODE FOR REACTIVITY 0
NFPA CODE FOR SPECIAL HAZARDS NONE

HMIS RATINGS:

HMIS CODE FOR HEALTH 1
HMIS CODE FOR FLAMMABILITY 0
HMIS CODE FOR REACTIVITY 0
HMIS CODE FOR PERSONAL PROTECTION SEE SECTION 8

ABBREVIATIONS:

N/A: DENOTES NO APPLICABLE INFORMATION FOUND OR AVAILABLE
CAS#: CHEMICAL ABSTRACTS SERVICE NUMBER
ACGIH: AMERICAN CONFERENCE OF GOVERNMENTAL INDUSTRIAL HYGIENISTS
OSHA: OCCUPATIONAL SAFETY AND HEALTH ADMINISTRATION
TLV: THRESHOLD LIMIT VALUE
PEL: PERMISSIBLE EXPOSURE LIMIT
STEL: SHORT TERM EXPOSURE LIMIT
NTP: NATIONAL TOXICOLOGY PROGRAM
IARC: INTERNATIONAL AGENCY FOR RESEARCH ON CANCER
R: RISK
S: SAFETY

PREPARED BY: ENVIRONET LLC.

THE INFORMATION CONTAINED HEREIN IS BASED ON DATA BELIEVED TO BE ACCURATE. HOWEVER, NO REPRESENTATION, WARRANTY, OR GUARANTEE IS MADE TO ITS ACCURACY, RELIABILITY OR COMPLETENESS. IT IS THE USER'S RESPONSIBILITY TO SATISFY HIMSELF AS TO THE SUITABILITY AND COMPLETENESS OF SUCH INFORMATION FOR ITS OWN PARTICULAR USE. BADGER FIRE PROTECTION ASSUMES NO RESPONSIBILITY FOR PERSONAL INJURY OR PROPERTY DAMAGE RESULTING FROM USE, HANDLING OR FROM CONTACT WITH THIS PRODUCT.

GUARANTEE

National Flooring Equipment, Inc. (National) warrants to the first consumer/purchaser that this National brand product (the #5600 Panther® Propane Powered Floor Prep System), when shipped in its original container, will be free from defective workmanship and materials and agrees that it will, at its option, either repair the defect or replace the defective product or part thereof at no charge to the purchaser for parts or labor for the period(s) set forth below.

This warranty does not apply to any appearance items of the product, to the additional excluded items set forth below, or to any product, the exterior of which has been damaged or defaced, which has been subjected to misuse, abnormal service or handling, or which has been altered or modified in design or construction.

In order to enforce the rights under this limited warranty, the purchaser should follow the steps set forth below and provide proof of purchase to National.

The limited warranty described herein is in addition to whatever implied warranties may be granted to purchasers by law. ALL IMPLIED WARRANTIES INCLUDING THE WARRANTIES OF MERCHANTABILITY AND FITNESS FOR USE ARE LIMITED TO THE PERIODS FROM THE DATE OF PURCHASE AS SET FORTH BELOW. Some states do not allow time limitations on an implied warranty, so the above limitation may not apply to you.

Neither the sales person of the seller, nor any other person, is authorized to make any other warranties other than those described herein, or to extend the duration of any warranties beyond the time period described herein on behalf of National.

The warranties described herein shall be the sole and exclusive warranties granted by National and shall be the sole and exclusive remedy available to the purchaser. Correction of defects in the manner and for the period of time described herein, shall constitute complete fulfillment of all liabilities and responsibilities of National to the purchaser with respect to the product and shall constitute full satisfaction of all claims, whether based on contract, negligence, strict liability or otherwise. In no event shall National be liable, or in any way responsible for any damage or defects in the product which were caused by repairs or attempted repairs performed by anyone other than National. Nor shall National be liable, or in any way responsible, for any incidental or consequential, economics or property damage. Some states do not allow the exclusion of incidental or consequential damages, so the above exclusion may not apply to you.

THIS WARRANTY GIVES YOU SPECIFIC LEGAL RIGHTS. YOU MAY ALSO HAVE OTHER RIGHTS WHICH VARY FROM STATE TO STATE.

WARRANTY PERIOD

The #5600 Panther® Propane Powered Floor Prep System is guaranteed to be free of manufacturer defective workmanship and in quality of materials for a period of one year.

Items excluded from warranty coverage, unless found and reported defective immediately upon removal from the original shipping container and before being used by the original purchaser.

A freight damage claim must be filed with the carrier by the purchaser, the shipper cannot file the freight claim.

To obtain service contact National Flooring Equipment, Inc. toll free at 800-245-0267 for a repair authorization number. COD freight returns will not be accepted. Freight collect shipments will not be accepted. Warranty repairs must be accompanied by date of purchase receipt and a return/repair authorization number.

RETURN SHEET

Company Name _____

Contact Name _____

Telephone Number _____

Approximate Usage (hours) _____

Problems Encountered _____

Check One: Repair

Do you wish to be contacted before repairing Yes No

Return

Contact National if a loaner is needed

Return Authorization Number _____ Date _____
required, contact National

Customer Number _____
if known

Purchased From _____
if not directly from National

INTERNAL USE ONLY	
Date Received	_____
Unit Serial Number	_____
Subject To Warranty	_____

5600 BLADE ORDER FORM

Part #	Description	Thickness	Quantity
#135	5" x 16" Blade	.062	
#147	4" x 6" Blade	.062	
#148	5" x 6" Blade	.062	
#363-2	3/4" x 8" Razor/Scraper Blade (50/pkg)	.032	
#368-8	7/8" x 8" Razor/Scraper Blade (50/pkg)	.045	
#368-12	7/8" x 12" Razor/Scraper Blade (50/pkg)	.045	
#368-15	7/8" x 15" Razor/Scraper Blade (50/pkg)	.045	
#6258-BU	3" x 12" Self-Scoring Blade - Bevel Up	.062	
#6259-BU	3" x 14" Self-Scoring Blade - Bevel Up	.062	
#6260-BD	3" x 6" Heavy Duty Ditching	.094	
#6276-BU	3" x 10" Self-Scoring Blade	.094	
#6277-BU	3" x 12" Self-Scoring Blade	.094	
#6278-BU	3" x 14" Self-Scoring Blade	.094	
#6281	3" x 8" Heavy Duty Blade	.094	
#6282	3" x 14" Heavy Duty Blade	.094	
#6283	3" x 27" Heavy Duty Blade	.094	
#6284	3" x 12" Heavy Duty Blade	.094	
#6285	3" x 6" Heavy Duty Blade	.094	
#6286	3" x 10" Heavy Duty Blade	.094	
#6290	3" x 6" Extra Heavy Duty Blade	.187	
#6291	3" x 8" Extra Heavy Duty Blade	.187	
#6292	3" x 12" Extra Heavy Duty Blade	.187	
#6293	3" x 14" Extra Heavy Duty Blade	.187	
#6294	3" x 27" Extra Heavy Duty Blade	.187	
#7050-200	3" x 6" Premium High Tempered Blade	.062	
#7050-201	3" x 8" Premium High Tempered Blade	.062	
#7050-202	3" x 10" Premium High Tempered Blade	.062	
#7050-203	3" x 12" Premium High Tempered Blade	.062	
#7050-204	3" x 14" Premium High Tempered Blade	.062	
#7050-205	3" x 27" Premium High Tempered Blade	.062	
#7070-2	4" x 2" Straight Shank Blades	.500	
#7070-3	4" x 3" Straight Shank Blades	.500	
#7070-4	4" x 4" Straight Shank Blades	.500	
#7070-6	4" x 6" Straight Shank Blades	.500	
#7071-2	4" x 2" Angle Shank Blades	.500	
#7071-3	4" x 3" Angle Shank Blades	.500	
#7071-4	4" x 4" Angle Shank Blades	.500	
#7071-6	4" x 6" Angle Shank Blades	.500	
#7072-2	4" x 2" Straight Shank w/Carbide Tip	.500	
#7072-3	4" x 3" Straight Shank w/Carbide Tip	.500	
#7072-4	4" x 4" Straight Shank w/Carbide Tip	.500	
#7072-6	4" x 6" Straight Shank w/Carbide Tip	.500	

5600 BLADE ORDER FORM

Part #	Description	Thickness	Quantity
#7074	5" x 27" Tile Box with 6" High Box	.187	
#7075-8	2" x 8" Tapered Cutting Head Shank	.300	
#7075-11	2" x 11" Tapered Cutting Head Shank	.300	
#7077-8	3.5" x 8" Tapered Cutting Head Shank	.300	
#7077-11	3.5" x 11" Tapered Cutting Head Shank	.300	
#7076-8	2" x 8" Tapered w/Carbide Tip	.300	
#7076-11	2" x 11" Tapered w/Carbide Tip	.300	
#7078-8	3.5" x 8" Tapered w/Carbide Tip	.300	
#7078-11	3.5" x 11" Tapered w/Carbide Tip	.300	
#7079-2	2" x 6" Ultra HD Ceramic Epoxy Blade	.500	
#7079-4	4" x 6" Ultra HD Ceramic Epoxy Blade	.500	
#7079-6	6" x 6" Ultra HD Ceramic Epoxy Blade	.500	
#7081	3" x 10" Increased Angle Blade	.062	
#7083	3" x 8" Increased Angle Blade	.062	

BILL TO:

Attn: _____

Company: _____

Address: _____

Phone: _____

SHIP TO:

Attn: _____

Company: _____

Address: _____

Phone: _____

TO ORDER:

Phone: 800-245-0267 or 763-535-8206

Fax: 800-648-7124 or 763-535-8255

Online: www.nationalequipment.com

All orders and payment terms to be verified prior to shipping.

National Flooring Equipment, Inc. • 9250 Xylon Avenue North • Minneapolis, MN 55445 U.S.A.

Phone 800-245-0267 or 763-535-8206 • Fax 800-648-7124 or 763-535-8255

Web Site: www.nationalequipment.com • E-Mail: info@nationalequipment.com